

JVC

SERVICE MANUAL

CD RECEIVER

KD-S747

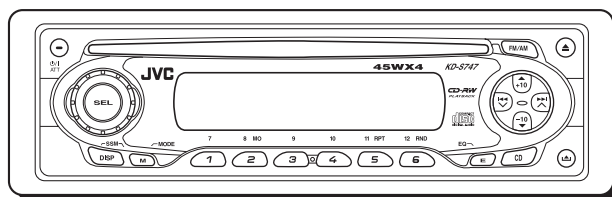
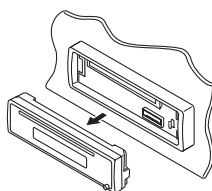

Area Suffix	
EE	----- Russian Federation

TABLE OF CONTENTS

1	Important Safety Precautions	1-2
2	Disassembly method	1-4
3	Adjustment.....	1-23
4	Description of major ICs.....	1-27

SECTION 1

Important Safety Precautions

1.1 Safety Precautions

 **CAUTION** Burrs formed during molding may be left over on some parts of the chassis. Therefore, pay attention to such burrs in the case of performing repair of this system.

 **CAUTION** Please use enough caution not to see the beam directly or touch it in case of an adjustment or operation check.

1.2 Preventing static electricity

Electrostatic discharge (ESD), which occurs when static electricity stored in the body, fabric, etc. is discharged, can destroy the laser diode in the traverse unit (optical pickup). Take care to prevent this when performing repairs.

1.2.1 Grounding to prevent damage by static electricity

Static electricity in the work area can destroy the optical pickup (laser diode) in devices such as DVD players. Be careful to use proper grounding in the area where repairs are being performed.

(1) Ground the workbench

Ground the workbench by laying conductive material (such as a conductive sheet) or an iron plate over it before placing the traverse unit (optical pickup) on it.

(2) Ground yourself

Use an anti-static wrist strap to release any static electricity built up in your body.

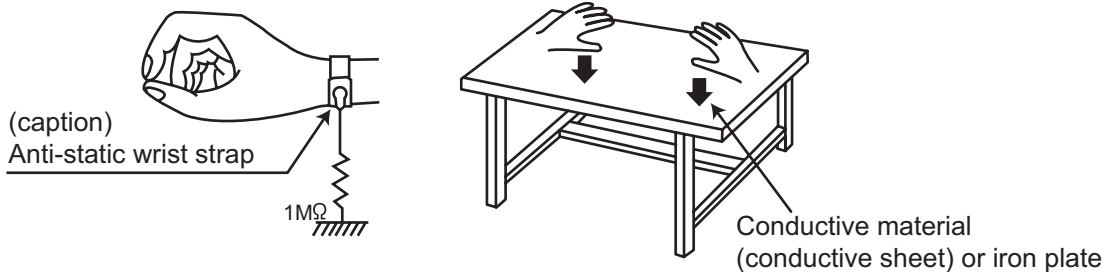

(3) Handling the optical pickup

- In order to maintain quality during transport and before installation, both sides of the laser diode on the replacement optical pickup are shorted. After replacement, return the shorted parts to their original condition. (Refer to the text.)
- Do not use a tester to check the condition of the laser diode in the optical pickup. The tester's internal power source can easily destroy the laser diode.

1.3 Handling the traverse unit (optical pickup)

- (1) Do not subject the traverse unit (optical pickup) to strong shocks, as it is a sensitive, complex unit.
- (2) Cut off the shorted part of the flexible cable using nippers, etc. after replacing the optical pickup. For specific details, refer to the replacement procedure in the text. Remove the anti-static pin when replacing the traverse unit. Be careful not to take too long a time when attaching it to the connector.
- (3) Handle the flexible cable carefully as it may break when subjected to strong force.
- (4) It is not possible to adjust the semi-fixed resistor that adjusts the laser power. Do not turn it.

1.4 Attention when traverse unit is decomposed

***Please refer to "Disassembly method" in the text for the CD pickup unit.**

- Apply solder to the short land before the flexible wire is disconnected from the connector on the CD pickup unit. (If the flexible wire is disconnected without applying solder, the CD pickup may be destroyed by static electricity.)
- In the assembly, be sure to remove solder from the short land after connecting the flexible wire.

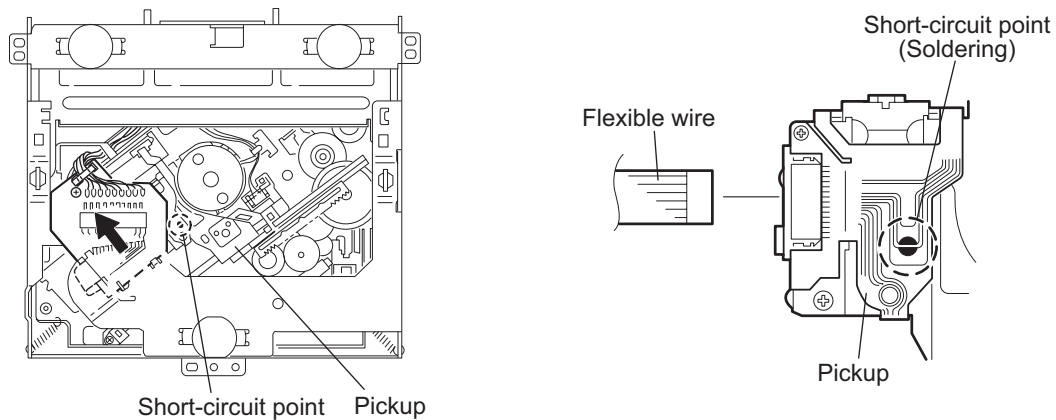

SECTION 2

Disassembly method

2.1 Main body

2.1.1 Removing the front panel assembly (See Fig.1)

- (1) Push the detach button in the lower right part of the front panel assembly and remove the front panel assembly in the direction of the arrow.

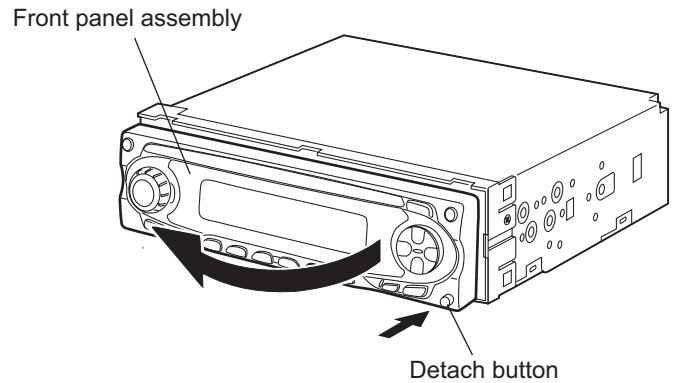

Fig.1

2.1.2 Removing the front chassis assembly (See Figs.2 and 3)

- Prior to performing the following procedure, remove the front panel assembly.

- (1) Remove the screw **A** on the both sides of the main body.
- (2) Release the two joints **a** and two joints **b** on both sides of the main body using a screwdriver, and remove the front chassis assembly forward.

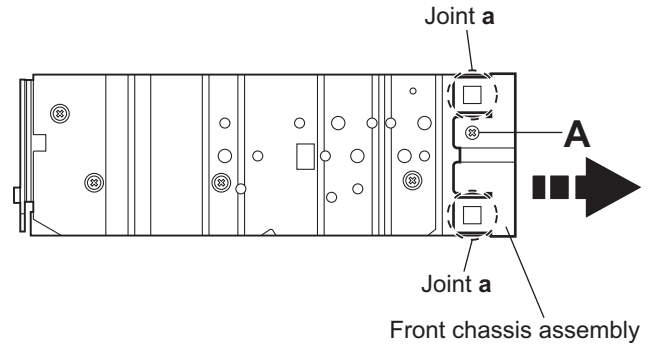

Fig.2

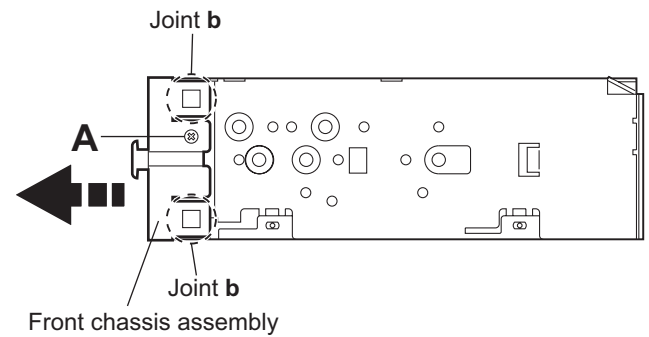

Fig.3

2.1.3 Removing the heat sink (See Fig.4)

- (1) Remove the two screws **B** and two screws **C** on the left side of the main body.

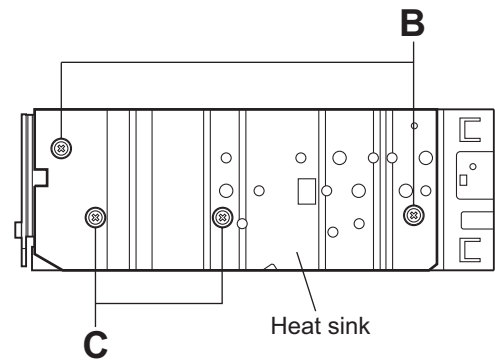

Fig.4

2.1.4 Removing the bottom cover (See Figs.5 and 6)

- Prior to performing the following procedure, remove the front panel assembly, front chassis assembly and heat sink.
- (1) Turn over the body and release the two joints **c**, two joints **d** and joint **e**.

CAUTION:

Do not damage the main board when releasing the joint **e** using a screwdriver. (See Figs.5 and 6)

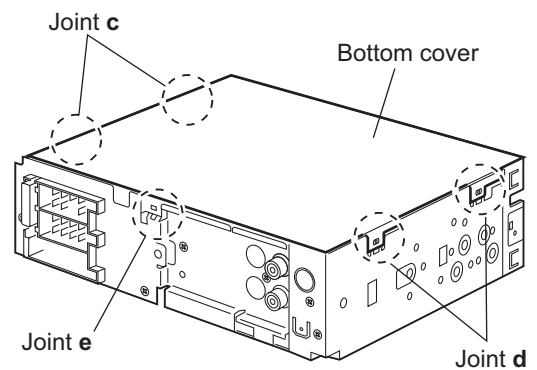

Fig.5

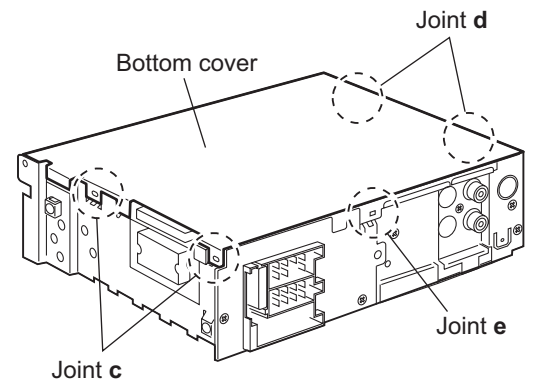

Fig.6

**2.1.5 Removing the rear bracket
(See Fig.7)**

- Prior to performing the following procedure, remove the front panel assembly, front chassis assembly, heat sink and bottom cover.
 - (1) Remove the three screws **D**, screw **E** and two screws **F** on the back of the body.
 - (2) Remove the rear bracket.

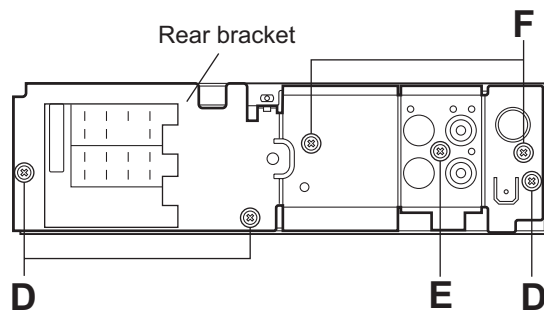

Fig.7

**2.1.6 Removing the main board
(See Fig.8)**

- Prior to performing the following procedure, remove the front panel assembly, front chassis assembly, heat sink, bottom cover and rear bracket.
 - (1) Remove the two screws **G** attaching the main board.
 - (2) Disconnect connector CN501 and remove the main board.

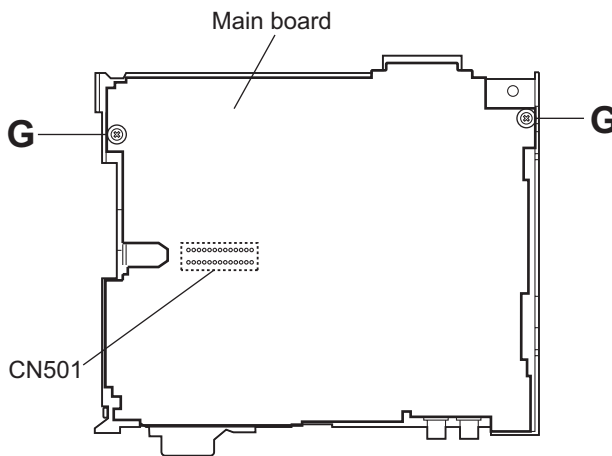

Fig.8

**2.1.7 Removing the CD mechanism assembly
(See Fig.9)**

- Prior to performing the following procedure, remove the front panel assembly, front chassis assembly, heat sink, bottom cover, rear bracket and main board.
 - (1) Remove the three screws **H**.

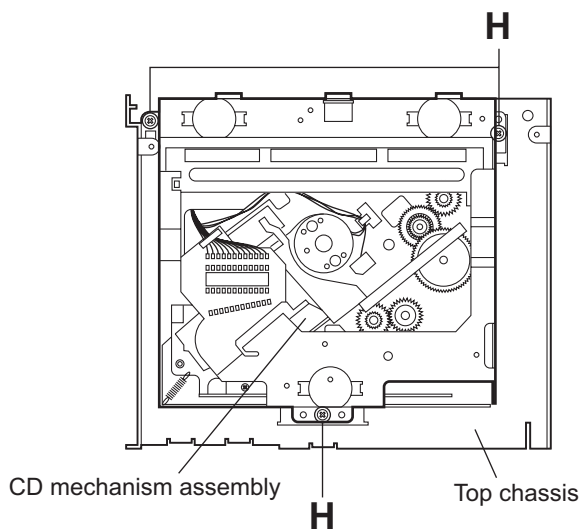

Fig.9

2.1.8 Removing the front board (See Figs.10 to 12)

- Prior to performing the following procedure, remove the front panel assembly.
 - (1) Remove the four screws **J** on the back side of the front panel assembly.
 - (2) Release the twelve joints **f**.
 - (3) Take out the front board.

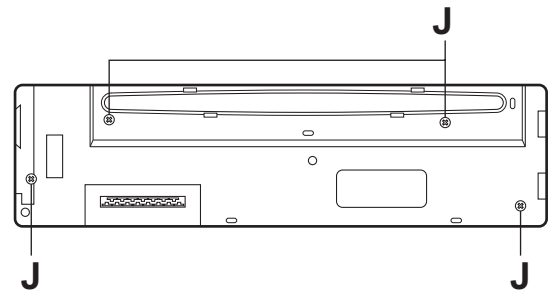

Fig.10

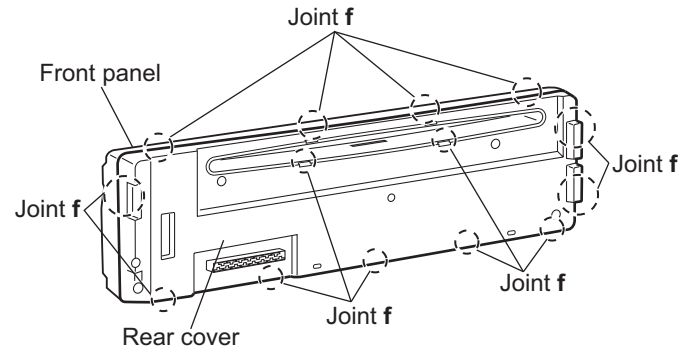

Fig.11

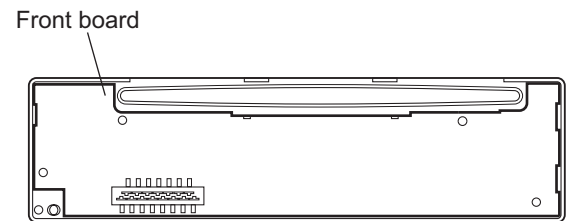

Fig.12

2.2 CD Mechanism Assembly

2.2.1 Removing the top cover (See Figs.1 and 2)

- (1) Remove the two screws **A** on the both side of the body.
- (2) Lift the front side of the top cover and move the top cover backward to release the two joints **a**.

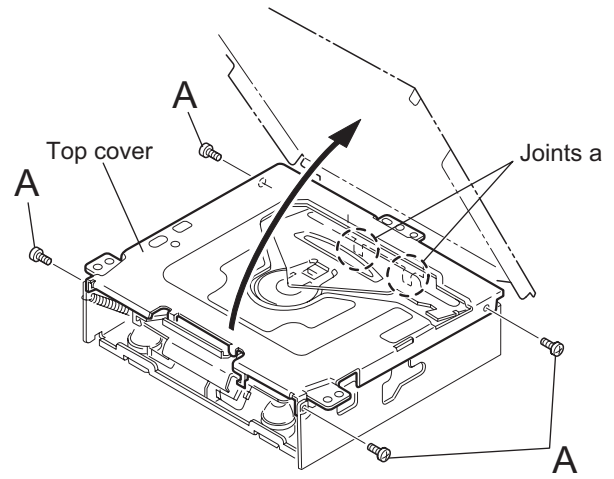

Fig.1

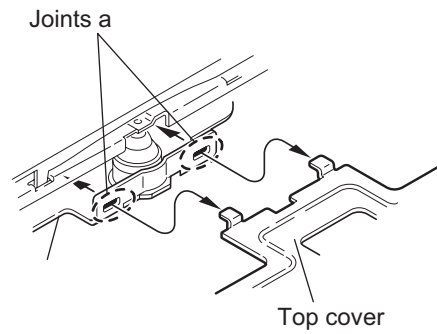

Fig.2

2.2.2 Removing the connector board (See Figs.3 to 5)

CAUTION:

Before disconnecting the flexible wire from the pickup, solder the short-circuit point on the pickup. No observance of this instruction may cause damage of the pickup.

- (1) Remove the screw **B** fixing the connector board.
- (2) Solder the short-circuit point on the connector board.
- (3) Disconnect the flexible wire from the pickup.
- (4) Move the connector board in the direction of the arrow to release the two joints **b**.
- (5) Unsolder the wire on the connector board if necessary.

CAUTION:

Unsolder the short-circuit point after reassembling.

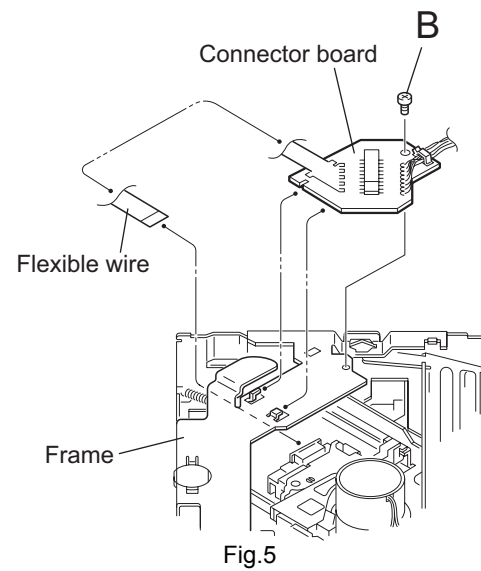
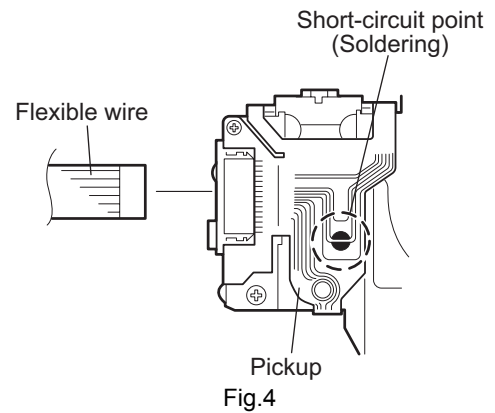
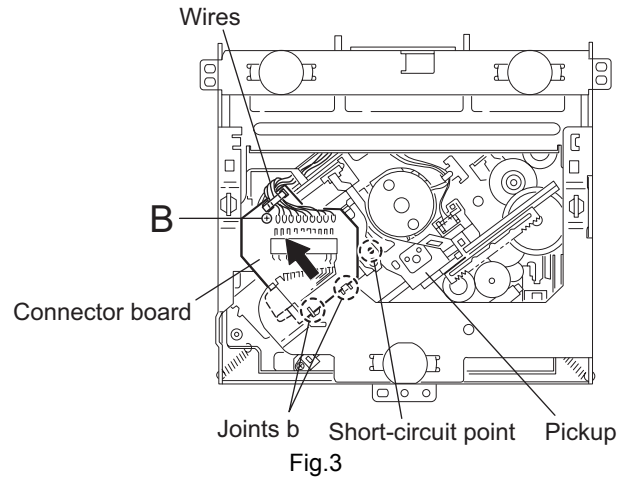

2.2.3 Removing the DET switch
(See Figs.6 and 7)

- (1) Extend the two tabs c of the feed sw. holder and pull out the switch.
- (2) Unsolder the DET switch wire if necessary.

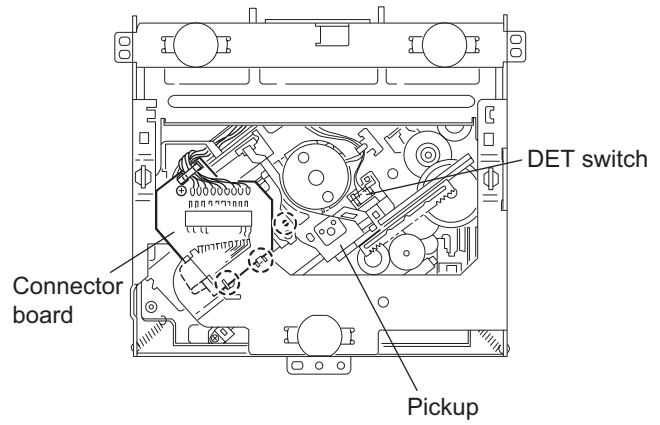

Fig.6

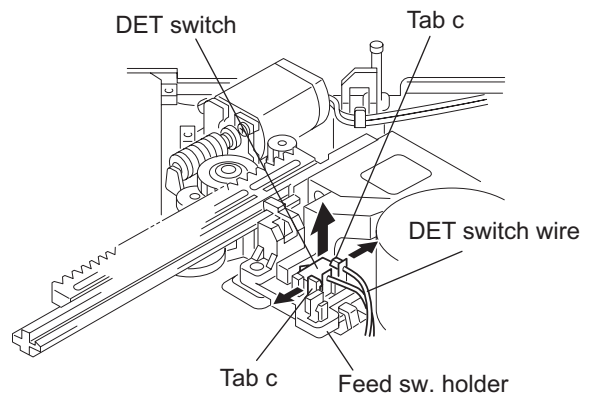

Fig.7

2.2.4 Removing the chassis unit (See Figs.8 and 9)

- Prior to performing the following procedure, remove the top cover and connector board.
- (1) Remove the two suspension springs (L) and (R) attaching the chassis unit to the frame.

CAUTION:

- The shape of the suspension spring (L) and (R) are different. Handle them with care.
- When reassembling, make sure that the three shafts on the underside of the chassis unit are inserted to the dampers certainly.

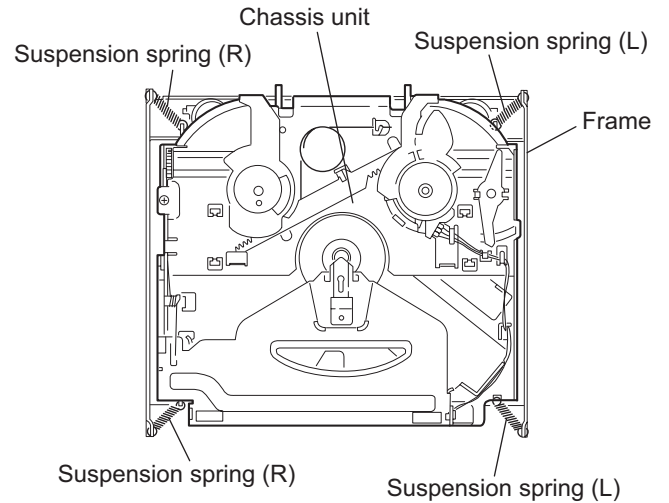

Fig.8

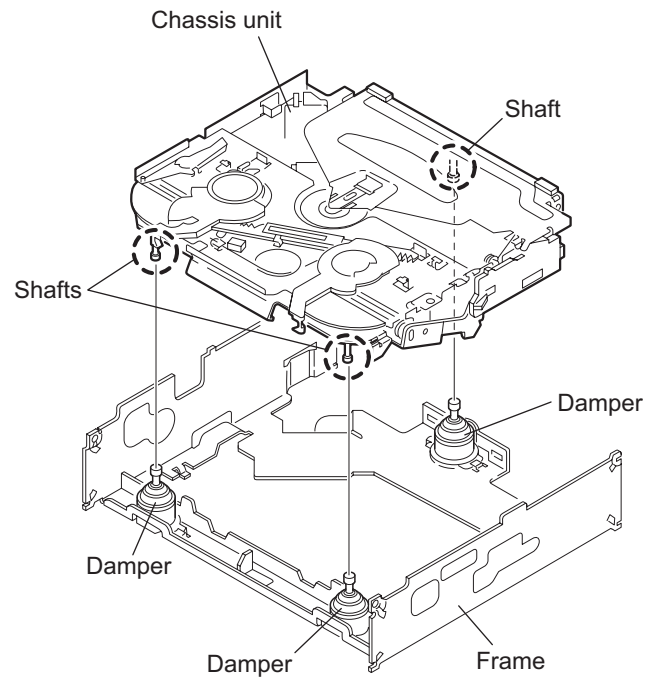
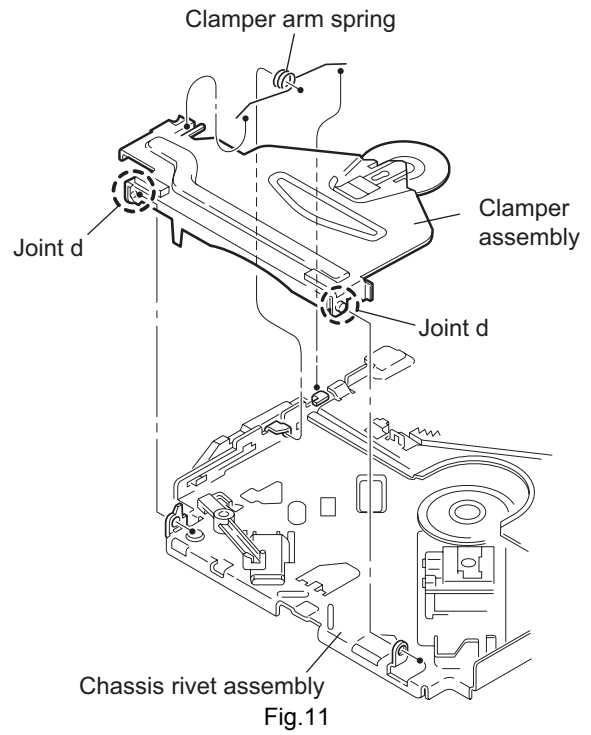
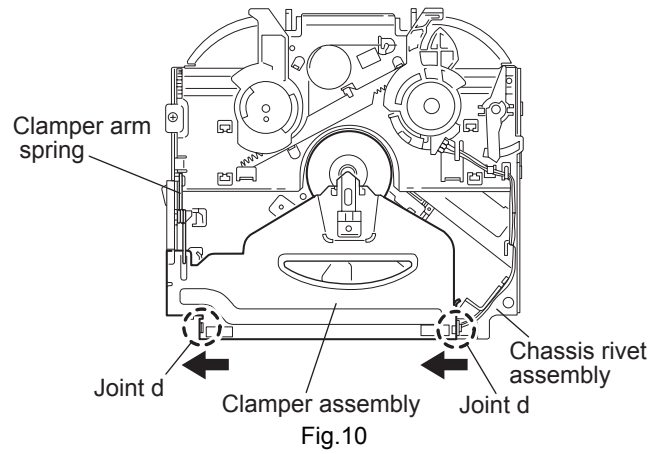

Fig.9

2.2.5 Removing the clamper assembly
(See Figs.10 and 11)

- Prior to performing the following procedure, remove the top cover.
- (1) Remove the clamper arm spring.
- (2) Move the clamper assembly in the direction of the arrow to release the two joints **d**.



2.2.6 Removing the loading / feed motor assembly (See Figs.12 and 13)

- Prior to performing the following procedure, remove the top cover, connector board and chassis unit.
 - (1) Remove the screw **C** and move the loading / feed motor assembly in the direction of the arrow to remove it from the chassis rivet assembly.
 - (2) Disconnect the wire from the loading / feed motor assembly if necessary.

CAUTION:

When reassembling, connect the wire from the loading / feed motor assembly to the flame as shown in Fig.12.

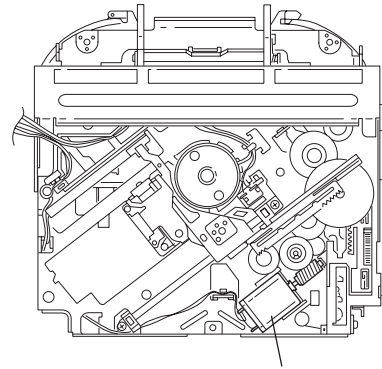

Loading / feed motor assembly
Fig.12

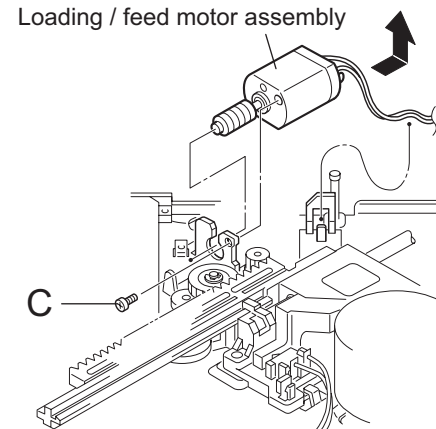

Fig.13

2.2.7 Removing the pickup unit
(See Figs.14 to 18)

- Prior to performing the following procedure, remove the top cover, connector board and chassis unit.
- (1) Remove the screw **D** and pull out the pu. shaft holder from the pu. shaft.
- (2) Remove the screw **E** attaching the feed sw. holder.
- (3) Move the part **e** of the pickup unit upward with the pu. shaft and the feed sw. holder, then release the joint **f** of the feed sw. holder in the direction of the arrow. The joint **g** of the pickup unit and the feed rack is released, and the feed sw. holder comes off.
- (4) Remove the pu. shaft from the pickup unit.
- (5) Remove the screw **F** attaching the feed rack to the pickup unit.

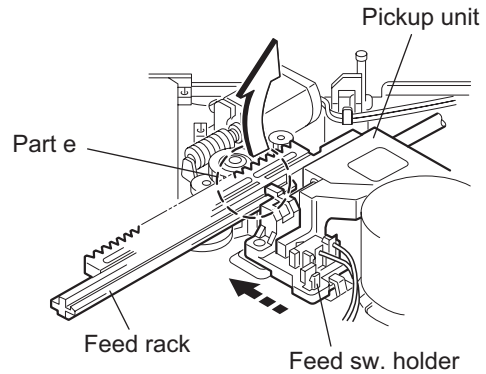

Fig.15

2.2.8 Reattaching the pickup unit
(See Figs.14 to 17)

- (1) Reattach the feed rack to the pickup unit using the screw **F**.
- (2) Reattach the feed sw. holder to the feed rack while setting the joint **g** to the slot of the feed rack and setting the part **f** of the feed rack to the switch of the feed sw. holder correctly.
- (3) As the feed sw. holder is temporarily attached to the pickup unit, set to the gear of the joint **g** and to the bending part of the chassis (joint **h**) at a time.

CAUTION:

Make sure that the part **i** on the underside of the feed rack is certainly inserted to the slot **j** of the change lock lever.

- (4) Reattach the feed sw. holder using the screw **E**.
- (5) Reattach the pu. shaft to the pickup unit. Reattach the pu. shaft holder to the pu. shaft using the screw **D**.

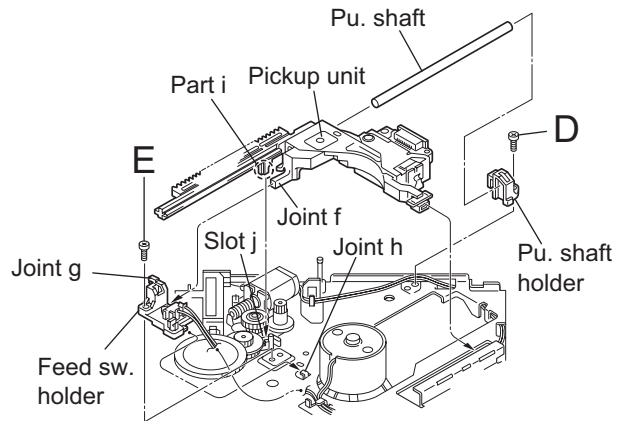

Fig.16

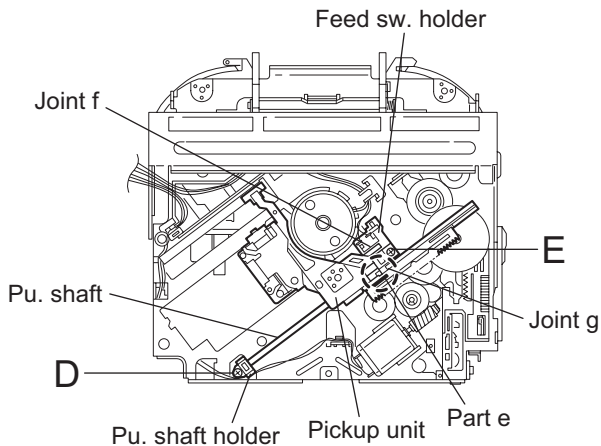

Fig.14

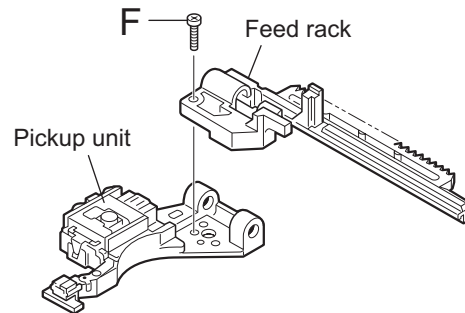

Fig.17

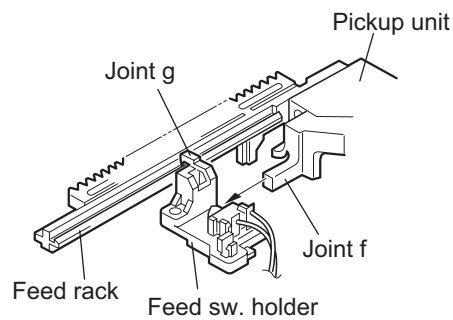

Fig.18

2.2.9 Removing the trigger arm (See Figs.19 and 20)

- Prior to performing the following procedure, remove the top cover, connector board and clamper unit.
- (1) Turn the trigger arm in the direction of the arrow to release the joint k and pull out upward.

CAUTION:

When reassembling, insert the part m and n of the trigger arm into the part p and q at the slot of the chassis rivet assembly respectively and join the joint k at a time.

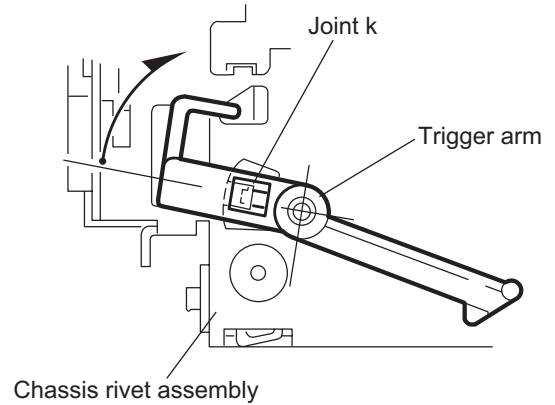

Fig.19

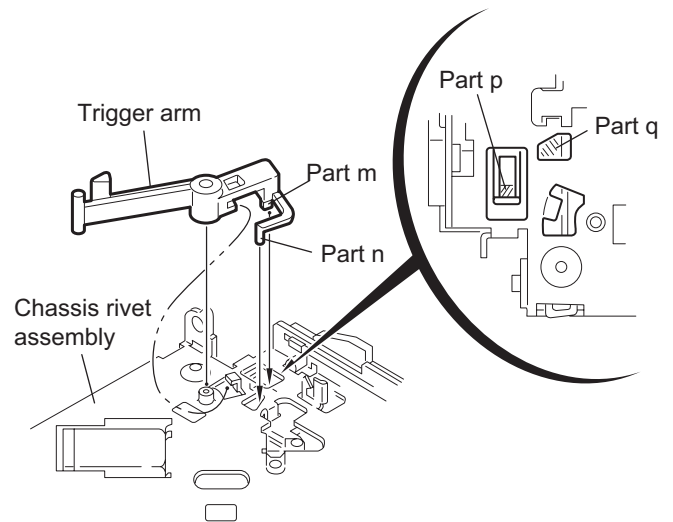

Fig.20

2.2.10 Removing the top plate assembly (See Fig.21)

- Prior to performing the following procedure, remove the top cover, connector board, chassis unit, and clamper assembly.
- (1) Remove the screw H.
- (2) Move the top plate assembly in the direction of the arrow to release the two joints r.
- (3) Unsolder the wire marked s if necessary.

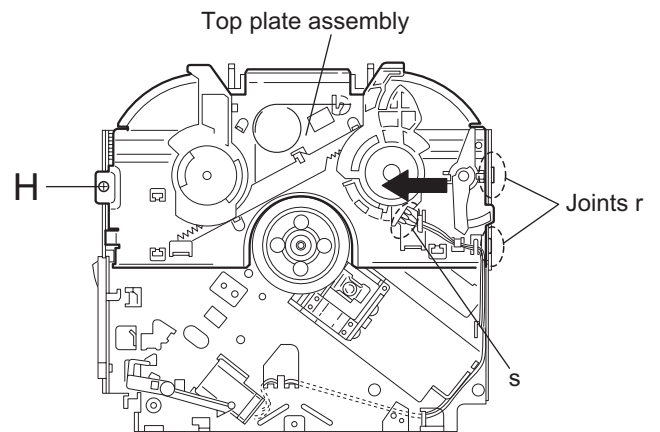

Fig.21

2.2.11 Removing the mode sw. / select lock arm (See Figs.22 and 23)

- Prior to performing the following procedure, remove the top plate assembly.
 - (1) Bring up the mode sw. to release from the link plate (joint t) and turn in the direction of the arrow to release the joint u.
 - (2) Unsolder the wire of the mode sw. marked s if necessary.
 - (3) Turn the select lock arm in the direction of the arrow to release the two joints v.
 - (4) The select lock arm spring comes off the select lock arm at the same time.

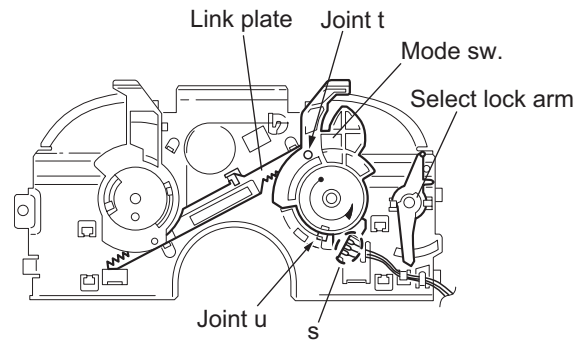

Fig.22

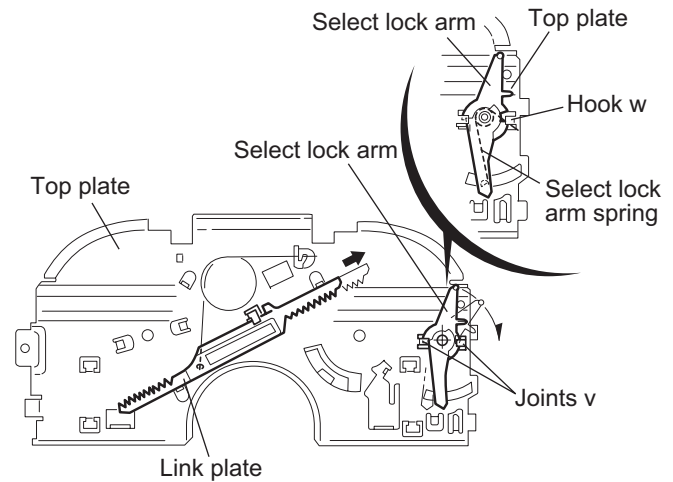

Fig.23

2.2.12 Reassembling the mode sw. / select lock arm (See Figs.24 to 26)

REFERENCE:

Reverse the above removing procedure.

- (1) Reattach the select lock arm spring to the top plate and set the shorter end of the select lock arm spring to the hook w on the top plate.
- (2) Set the other longer end of the select lock arm spring to the boss x on the underside of the select lock arm, and join the select lock arm to the slots (joint v). Turn the select lock arm as shown in the figure.
- (3) Reattach the mode sw. while setting the part t to the first peak of the link plate gear, and join the joint u.

CAUTION:

When reattaching the mode sw., check if the points y and z are correctly fitted and if each part operates properly.

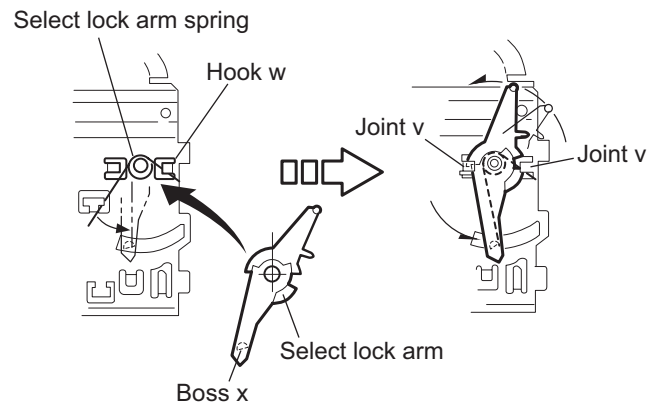

Fig.24

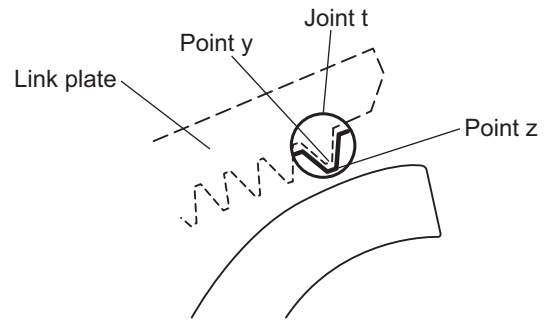

Fig.25

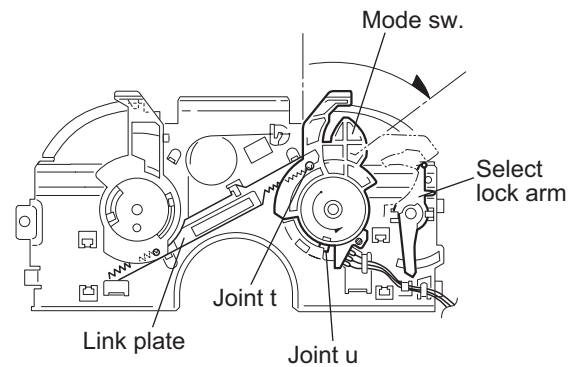

Fig.26

2.2.13 Removing the select arm R / link plate
(See Figs.27 and 28)

• Prior to performing the following procedure, remove the top plate assembly.

- (1) Bring up the select arm R to release from the link plate (joint a') and turn as shown in the figure to release the two joints b' and joint c'.
- (2) Move the link plate in the direction of the arrow to release the joint d'. Remove the link plate spring at the same time.

REFERENCE:

Before removing the link plate, remove the mode sw..

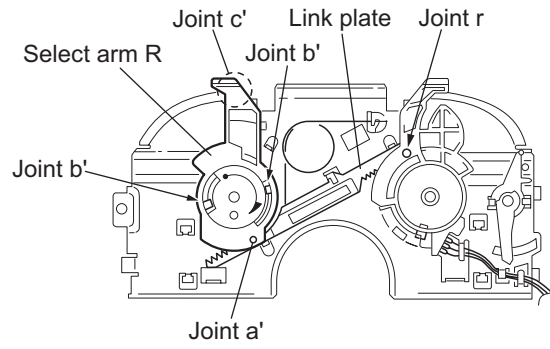

Fig.27

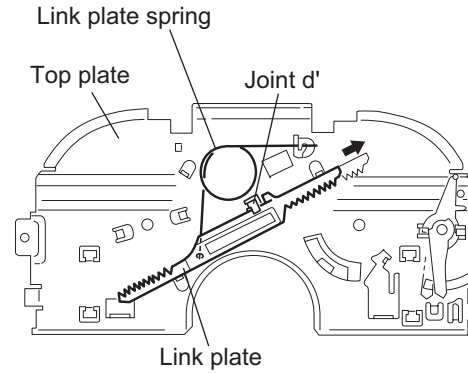

Fig.28

2.2.14 Reattaching the Select arm R / link plate
(See Figs.29 and 30)

REFERENCE:

Reverse the above removing procedure.

- (1) Reattach the link plate spring.
- (2) Reattach the link plate to the link plate spring while joining them at joint d'.
- (3) Reattach the joint a' of the select arm R to the first peak of the link plate while joining the two joints b' with the slots. Then turn the select arm R as shown in the figure. The top plate is joined to the joint c'.

CAUTION:

When reattaching the select arm R, check if the points e' and f' are correctly fitted and if each part operates properly.

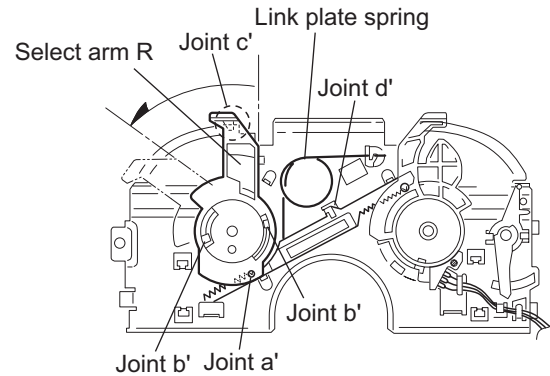

Fig.29

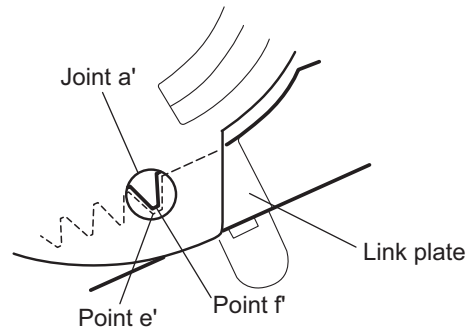

Fig.30

2.2.15 Removing the loading roller assembly
(See Figs.31 to 33)

- Prior to performing the following procedure, remove the clamper assembly and top plate assembly.
- (1) Push inward the loading roller assembly on the gear side and detach it upward from the slot of the joint **g'** of the lock arm rivet assembly.
- (2) Detach the loading roller assembly from the slot of the joint **h'** of the lock arm rivet assembly.

The roller guide comes off the gear section of the loading roller assembly.

Remove the roller guide and the HL washer from the shaft of the loading roller assembly.

- (3) Remove the screw **J** attaching the lock arm rivet assembly.
- (4) Push the shaft at the joint **i'** of the lock arm rivet assembly inward to release the lock arm rivet assembly from the slot of the L side plate.
- (5) Extend the lock arm rivet assembly outward and release the joint **j'** from the boss of the chassis rivet assembly. The roller guide springs on both sides come off at the same time.

CAUTION:

When reassembling, reattach the left and right roller guide springs to the lock arm rivet assembly before reattaching the lock arm rivet assembly to the chassis rivet assembly. Make sure to fit the part **k'** of the roller guide spring inside of the roller guide. (Refer to Fig.34.)

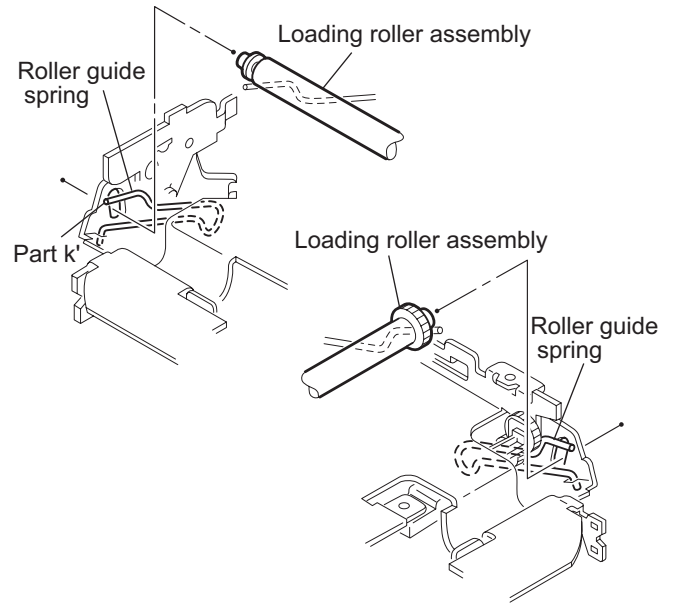

Fig.32

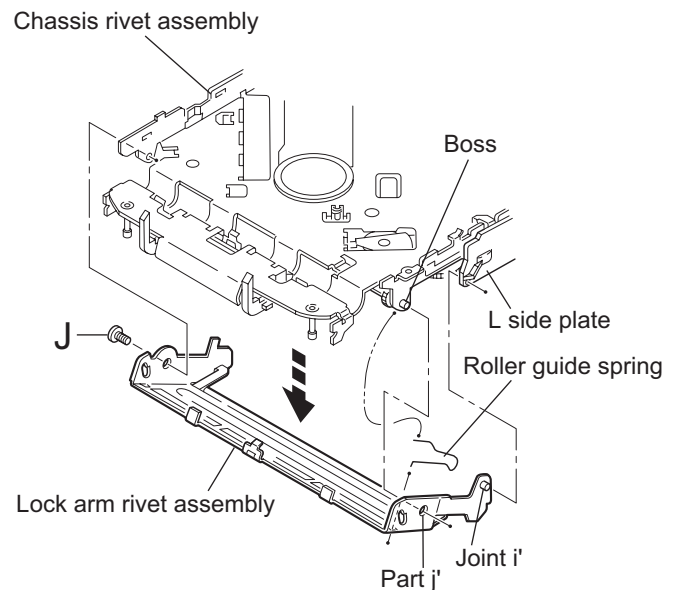

Fig.33

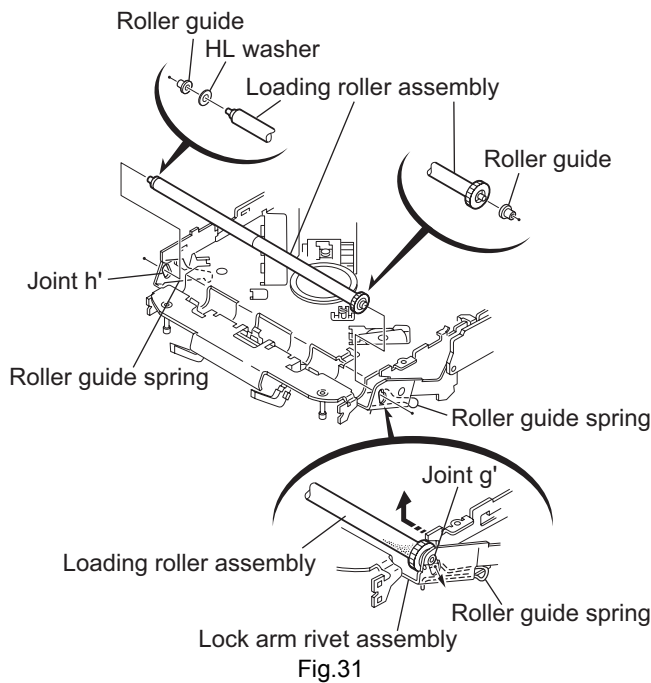

Fig.31

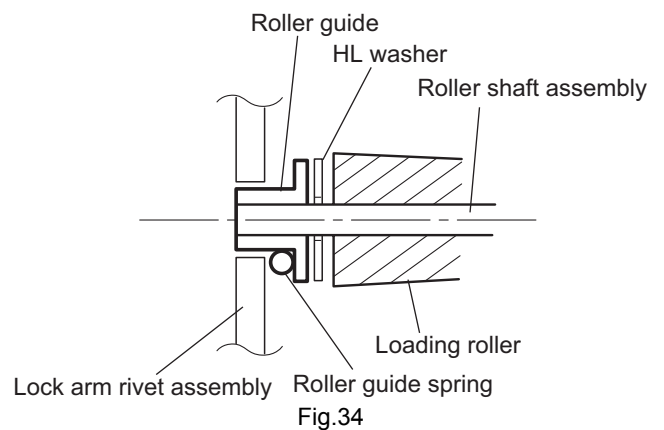

Fig.34

2.2.16 Removing the loading gear 5, 6 and 7 (See Figs.35 and 36)

- Prior to performing the following procedure, remove the top cover, chassis unit, pickup unit and top plate assembly.
 - (1) Remove the screw **K** attaching the loading gear bracket.
 - The loading gear 6 and 7 come off the loading gear bracket.
 - (2) Pull out the loading gear 5.

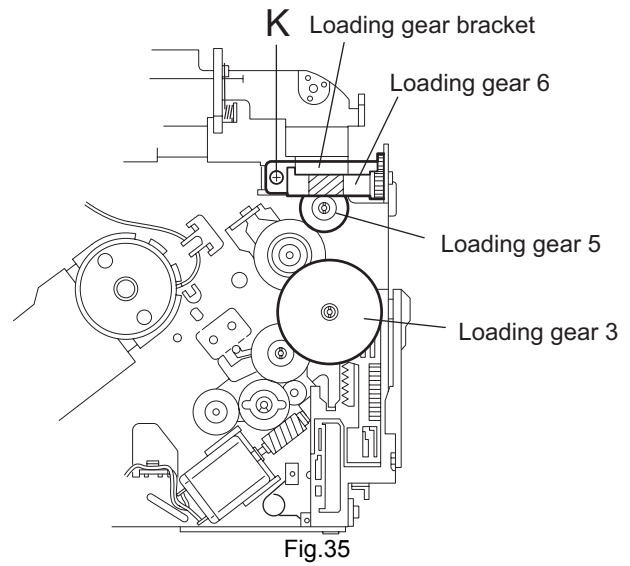

Fig.35

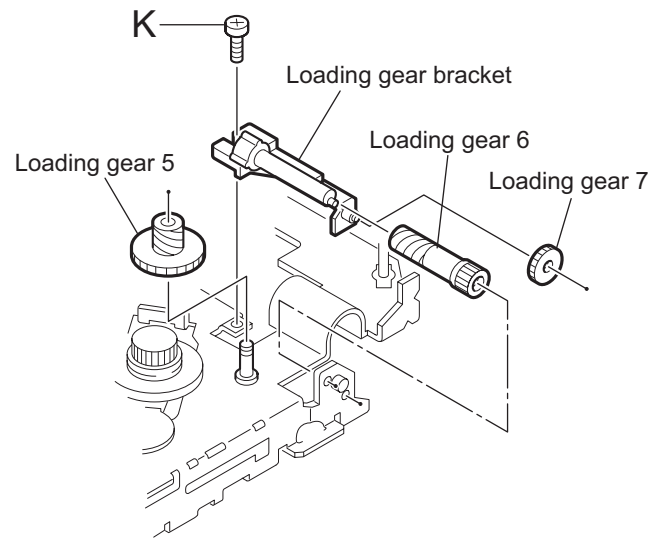
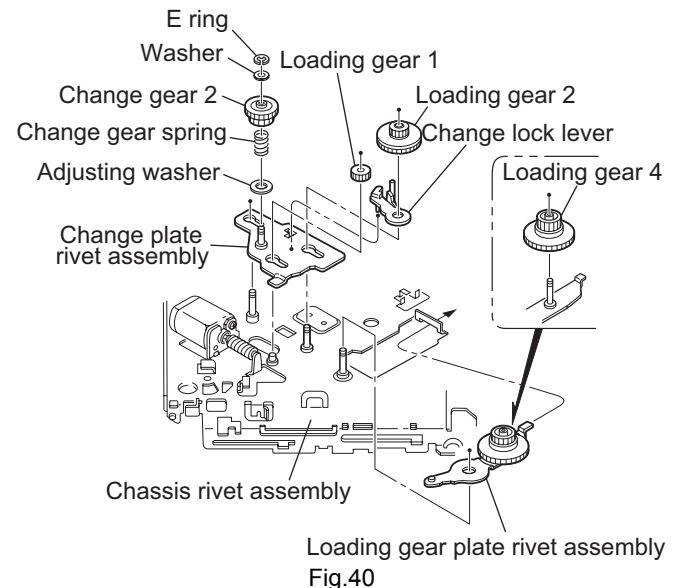
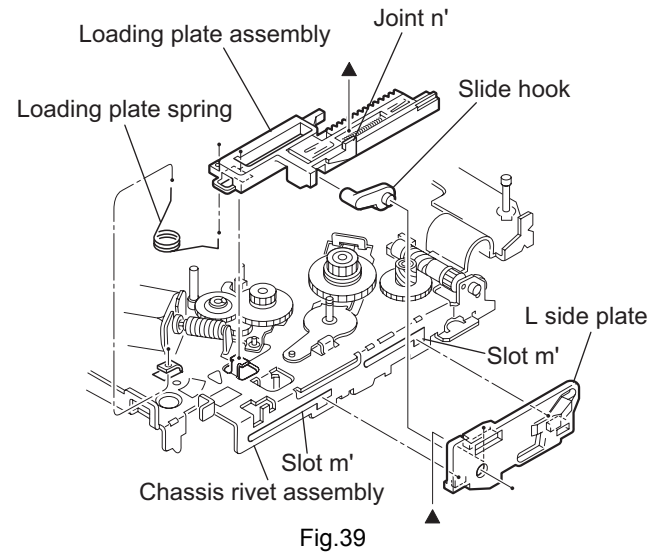
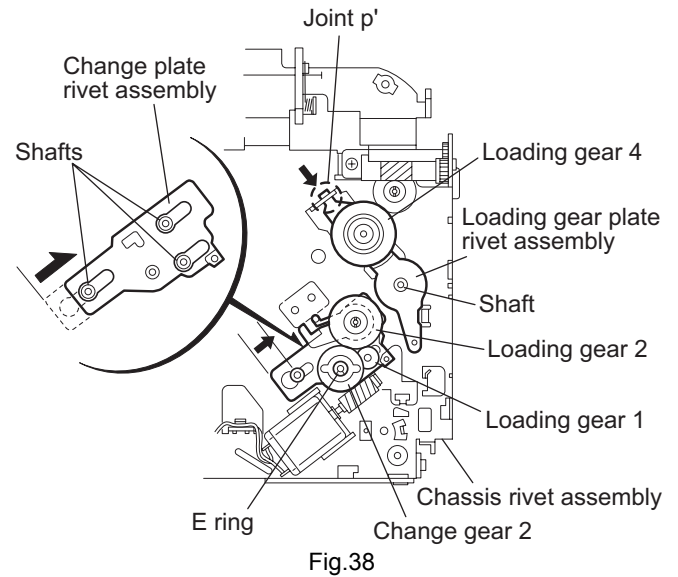
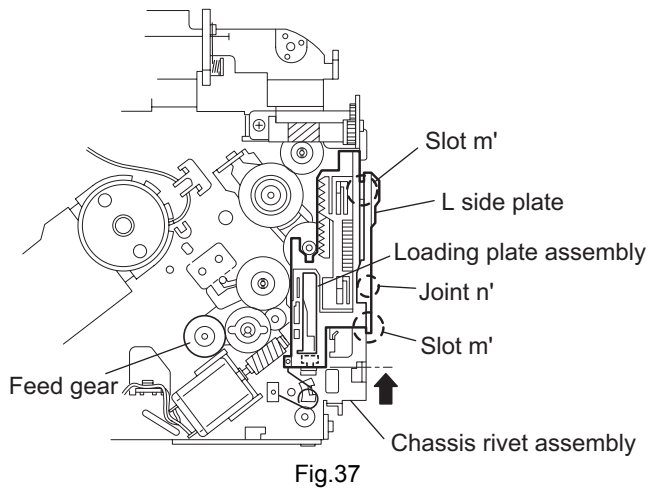

Fig.36

2.2.17 Removing the gears (See Figs.37 to 40)

- Prior to performing the following procedure, remove the top cover, chassis unit, top plate assembly and pickup unit.
- Pull out the loading gear 3. (See Fig.35.)
 - (1) Pull out the feed gear.
 - (2) Move the loading plate assembly in the direction of the arrow to release the L side plate from the two slots m' of the chassis rivet assembly. (See Fig.37.)
 - (3) Detach the loading plate assembly upward from the chassis rivet assembly while releasing the joint n'. Remove the slide hook and loading plate spring from the loading plate assembly.
 - (4) Pull out the loading gear 2 and remove the change lock lever.
 - (5) Remove the E ring and washer attaching the changer gear 2.
 - (6) The changer gear 2, change gear spring and adjusting washer come off.
 - (7) Remove the loading gear 1.
 - (8) Move the change plate rivet assembly in the direction of the arrow to release from the three shafts of the chassis rivet assembly upward. (See Fig.38.)
 - (9) Detach the loading gear plate rivet assembly from the shaft of the chassis rivet assembly upward while releasing the joint p'. (See Figs.38 and 40.)
 - (10) Pull out the loading gear 4.



2.2.18 Removing the turn table / spindle motor (See Figs.41 and 42)

- Prior to performing the following procedure, remove the top cover, connector board, chassis unit and clasper assembly.
 - (1) Remove the two screws **L** attaching the spindle motor assembly through the slot of the turn table on top of the body.
 - (2) Unsolder the wire on the connector board if necessary.

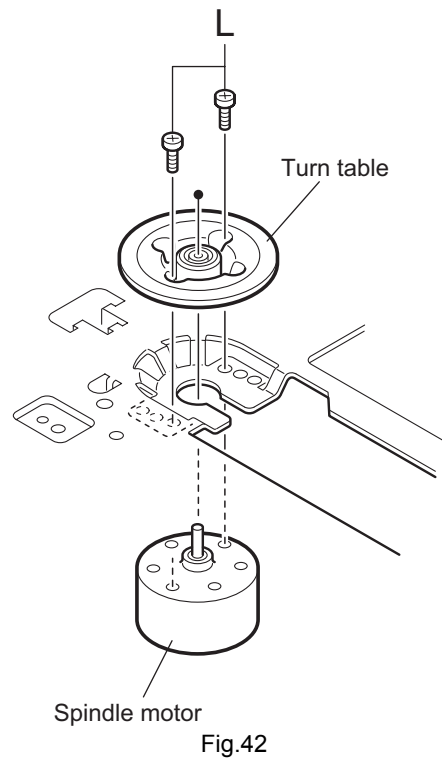
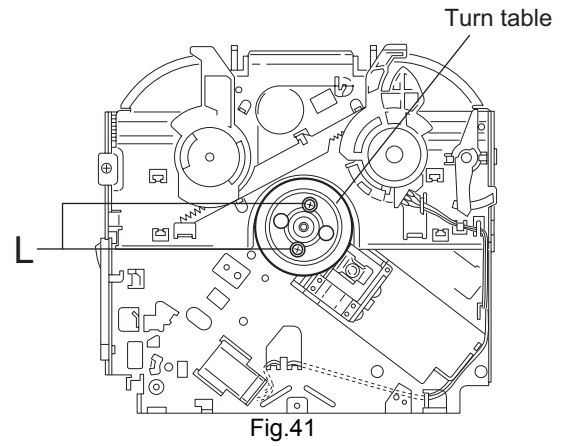

SECTION 3 Adjustment

3.1 Adjustment method

■ Test instruments required for adjustment

1. Digital oscilloscope (100MHz)
2. AM Standard signal generator
3. FM Standard signal generator
4. Stereo modulator
5. Electric voltmeter
6. Digital tester
7. Tracking offset meter
8. Test Disc JVC :CTS-1000
9. Extension cable for check
EXTSH002-22P[×] 1

■ Standard volume position

Balance and Bass & Treble volume : Indication "0"
Loudness : OFF

■ Frequency Band

FM1/FM2 87.5MHz ~ 108.0MHz
FM3 65.0MHz ~ 74.0MHz
MW 522kHz ~ 1620kHz
LW 144kHz ~ 279kHz

■ Dummy load

Exclusive dummy load should be used for AM, and FM. For FM dummy load, there is a loss of 6dB between SSG output and antenna input. The loss of 6dB need not be considered since direct reading of figures are applied in this working standard.

■ Standard measuring conditions

Power supply voltage DC14.4V(11~16V)
Load impedance 20Kohm(2 Speakers connection)
Output Level Line out 2.0V (Vol. MAX)

■ How to connect the extension cable for adjusting

* The cardboard is cut in a suitable size.
uses for the insulation stand of mechanism.

Caution:

Be sure to attach the heat sink and rear bracket onto the power amplifier IC301 and regulator IC901 respectively, before supply the power.

If voltage is applied without attaching these parts, the power amplifier IC and regulator IC will be destroyed by heat.

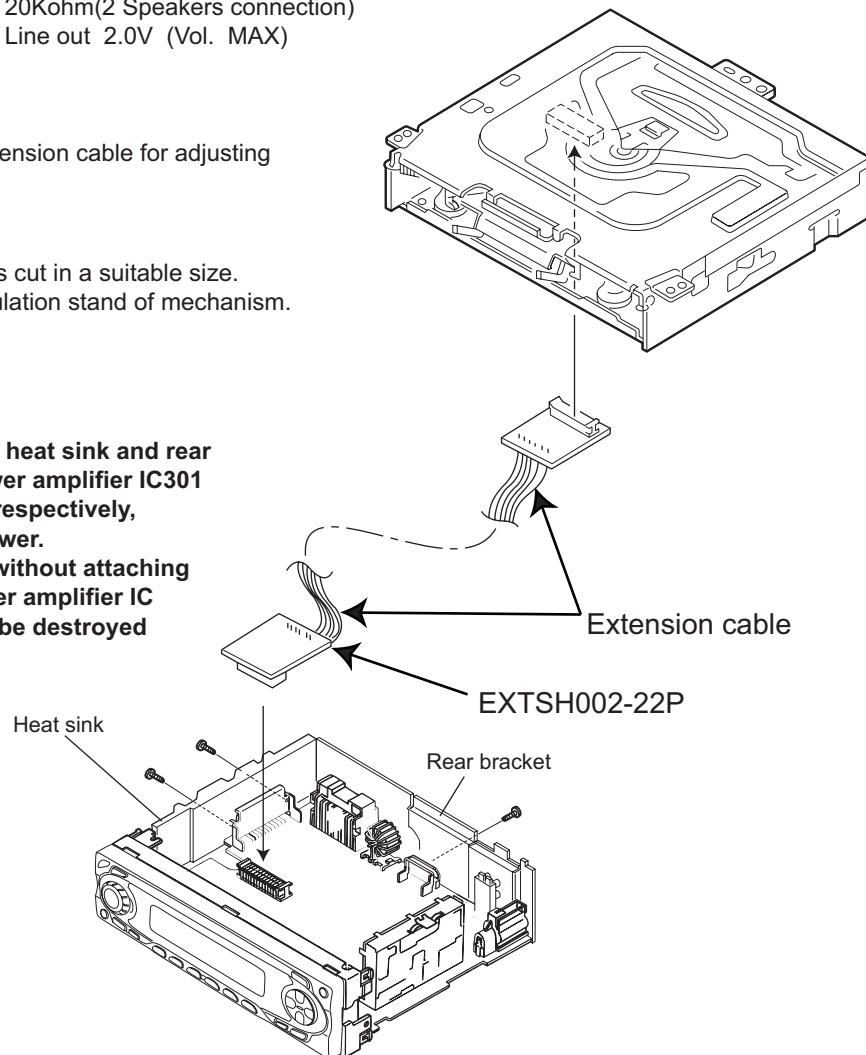

3.2 Troubleshooting

3.2.1 Feed section

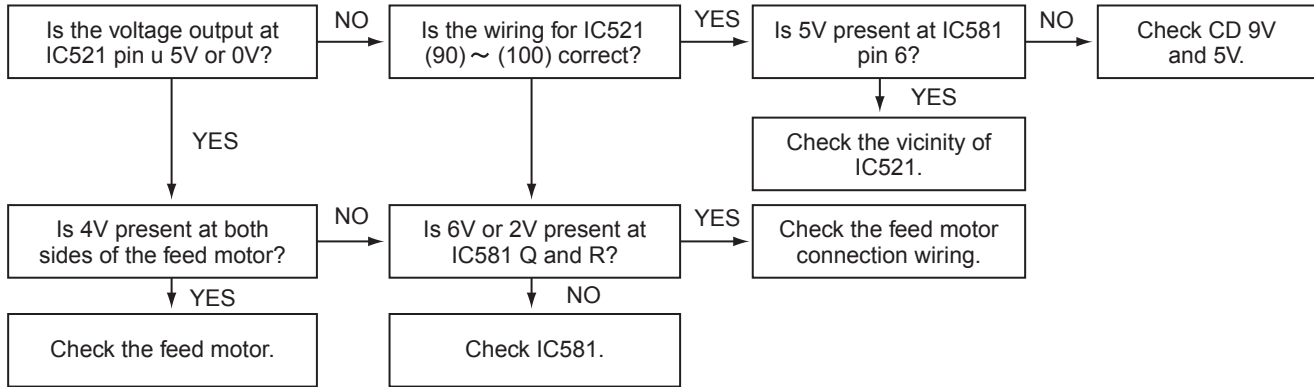

3.2.2 Focus section

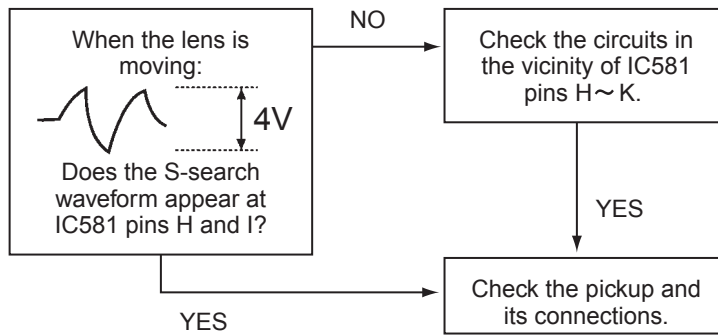

3.2.3 Spindle section

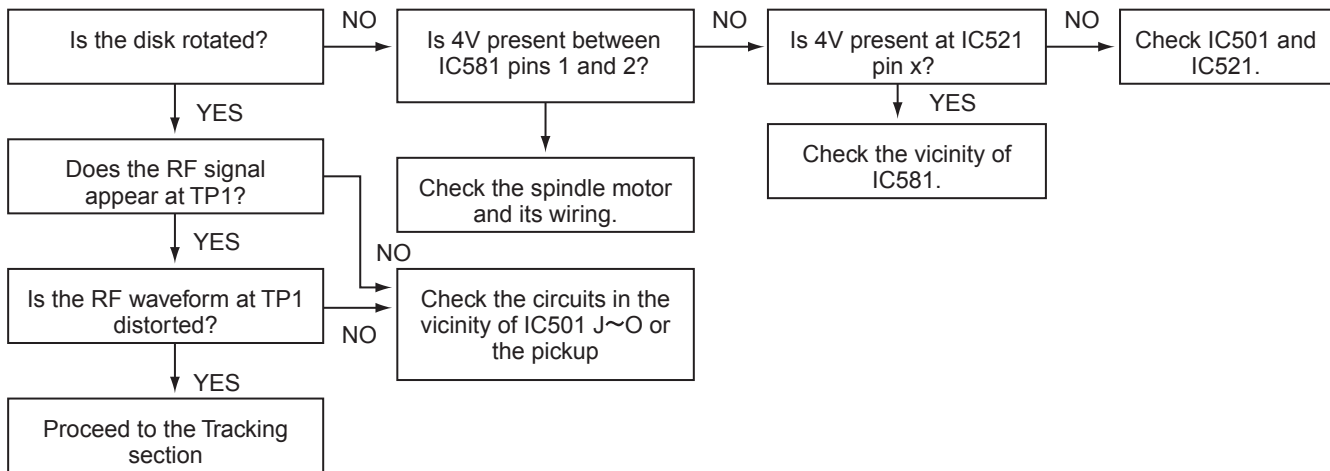

3.2.4 Tracking section

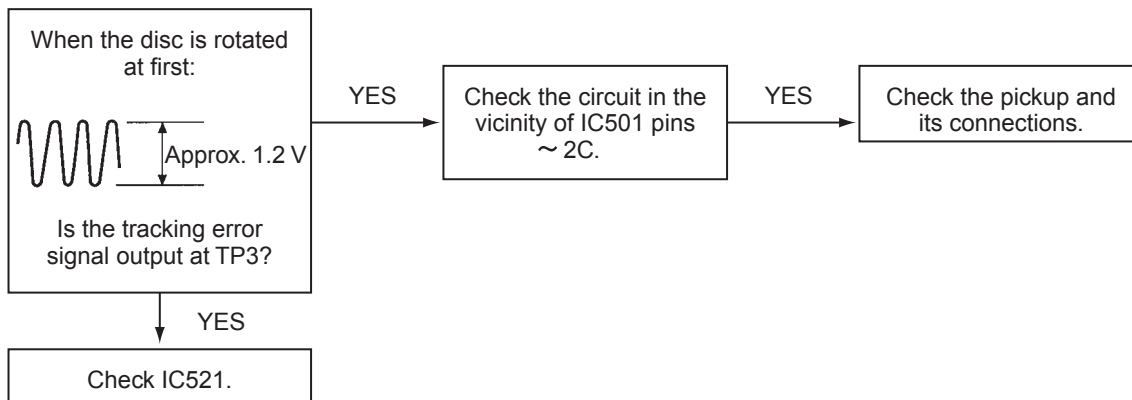

3.2.5 Signal processing section

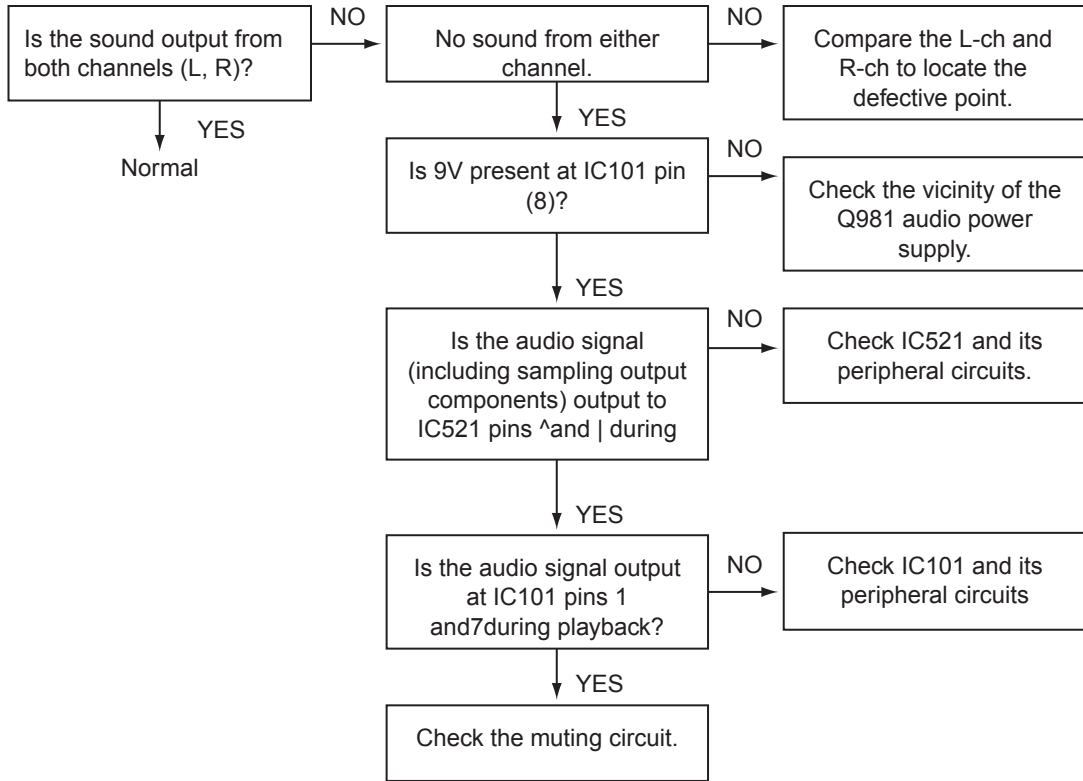

3.3 Maintenance of laser pickup

(1) Cleaning the pick up lens

Before you replace the pick up, please try to clean the lens with a alcohol soaked cotton swab.

(2) Life of the laser diode

When the life of the laser diode has expired, the following symptoms will appear.

- The level of RF output (EFM output: amplitude of eye pattern) will be low.

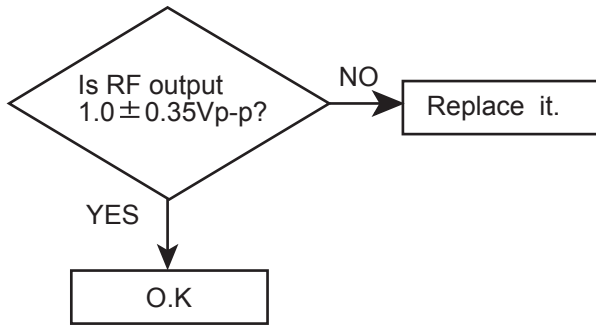

(3) Semi-fixed resistor on the APC PC board

The semi-fixed resistor on the APC printed circuit board which is attached to the pickup is used to adjust the laser power. Since this adjustment should be performed to match the characteristics of the whole optical block, do not touch the semi-fixed resistor.

If the laser power is lower than the specified value, the laser diode is almost worn out, and the laser pickup should be replaced.

If the semi-fixed resistor is adjusted while the pickup is functioning normally, the laser pickup may be damaged due to excessive current.

3.4 Replacement of laser pickup

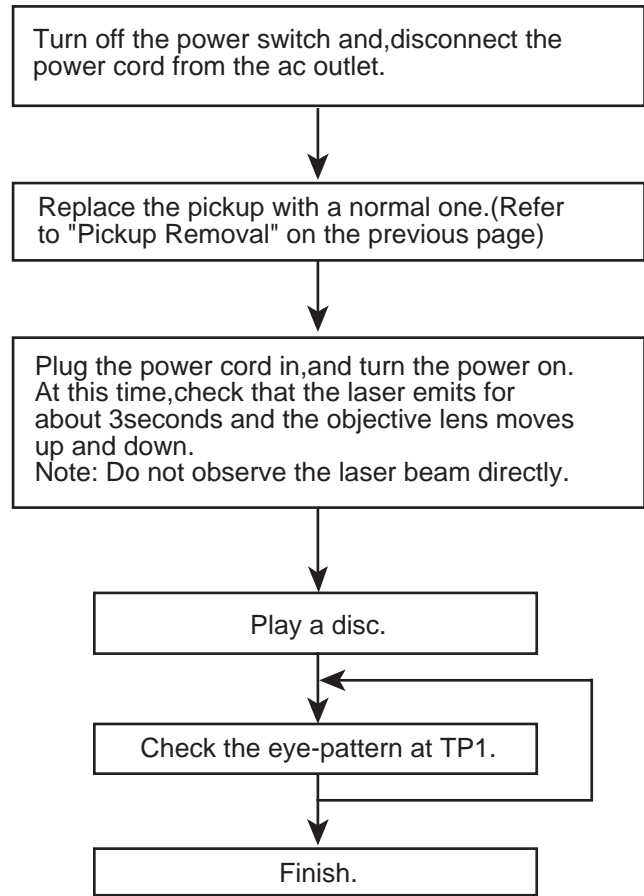

SECTION 4 Description of major ICs

4.1 HA13164A (IC901) : Regulator

- Terminal layout

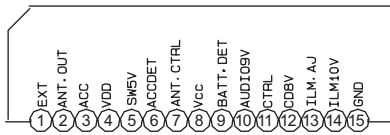

- Block diagram

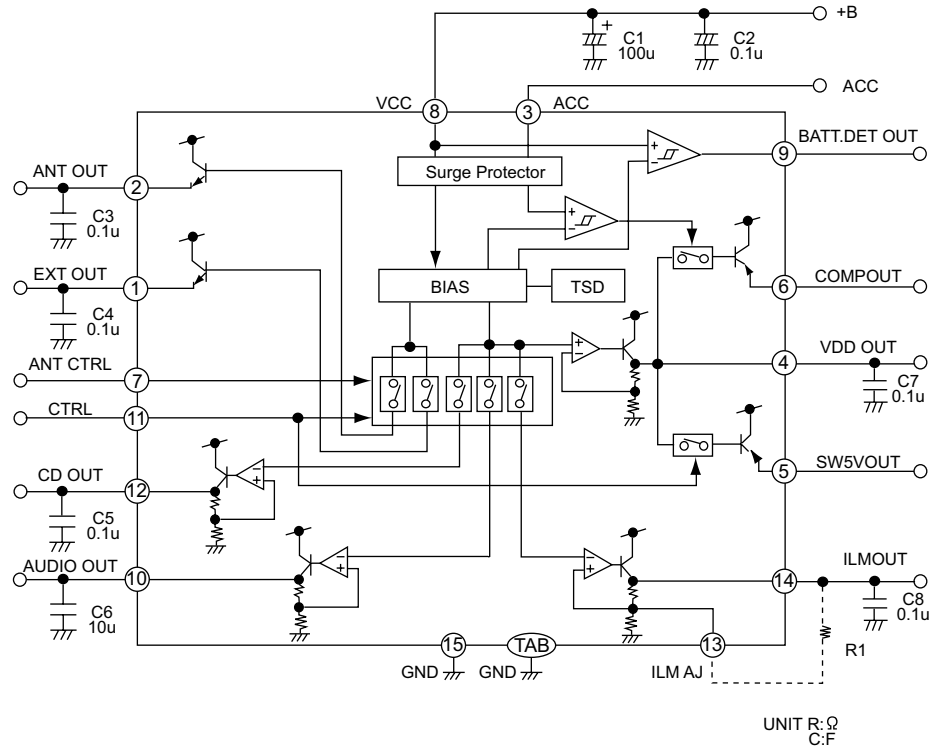

note1) TAB (header of IC) connected to GND

- Pin function

Pin No.	Symbol	Function
1	EXTOUT	Output voltage is VCC-1 V when M or H level applied to CTRL pin.
2	ANTOUT	Output voltage is VCC-1 V when M or H level to CTRL pin and H level to ANT-CTRL.
3	ACCIN	Connected to ACC.
4	VDDOUT	Regular 5.7V.
5	SW5VOUT	Output voltage is 5V when M or H level applied to CTRL pin.
6	COMPOUT	Output for ACC detector.
7	ANT CTRL	L:ANT output OFF H:ANT output ON
8	VCC	Connected to VCC.
9	BATT DET	Low battery detect.
10	AUDIO OUT	Output voltage is 9V when M or H level applied to CTRL pin.
11	CTRL	L:BIAS OFF M:BIAS ON H:CD ON
12	CD OUT	Output voltage is 8V when H level applied to CTRL pin.
13	ILM AJ	Adjustment pin for ILM output voltage.
14	ILM OUT	Output voltage is 10V when M or H level applied to CTRL pin.
15	GND	Connected to GND.

4.2 LA4743K (IC301) : Power amp.

- Block diagram

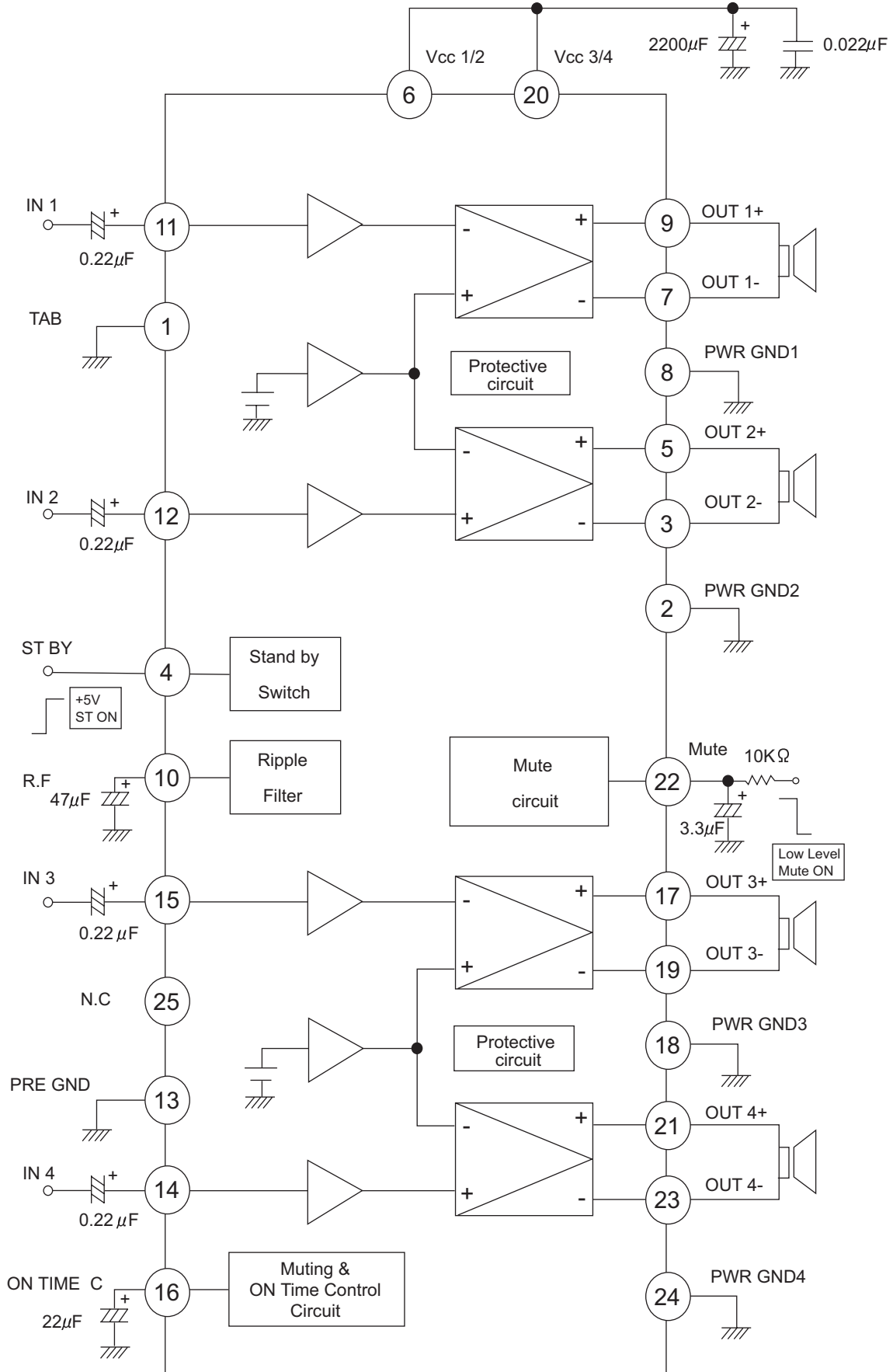

- Pin layout

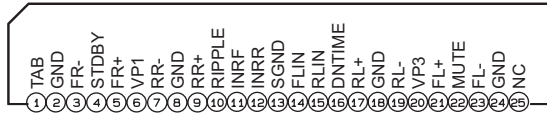

- Pin function

Pin No.	Symbol	Function	Pin No.	Symbol	Function
1	TAB	Header of IC	14	FLIN	Front Lch input
2	GND	Power GND	15	RLIN	Rear Lch input
3	FR-	Output(-) for front Rch	16	ONTIME	Power on time control
4	STDBY	Stand by input	17	RL+	Output (+) for rear Lch
5	FR+	Output (+) for front Rch	18	GND	Power GND
6	VP1	Power input	19	RL-	Output (-) for rear Lch
7	RR-	Output (-) for rear Rch	20	VP3	Power input
8	GND	Power GND	21	FL+	Output (+) for front
9	RR+	Output (+) for rear Rch	22	MUTE	Muting control input
10	RIPPLE	Ripple filter	23	FL-	Output (-) for front
11	RRIN	Rear Rch input	24	GND	Power GND
12	FRIN	Front Rch input	25	NC	Non connection
13	SGND	Signal GND			

4.3 LA6579H-X (IC561) : 4-Channel bridge driver

- Pin layout & Block diagram

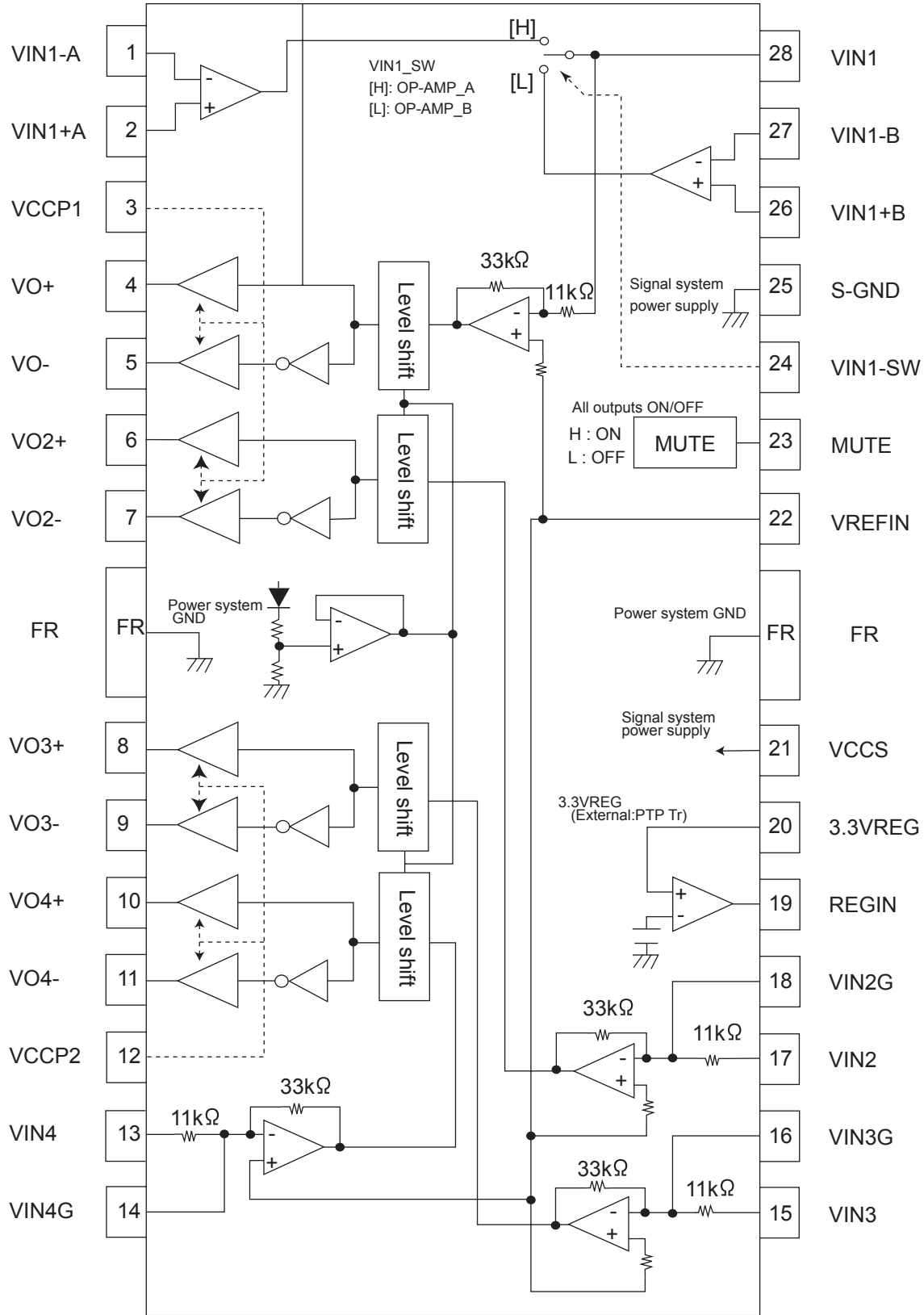

- Pin function

Pin No.	Symbol	Function
1	VIN1-A	CH1 input AMP_inverted input
2	VIN1+A	CH1 input AMP_non-inverted input
3	VCCP1	CH1 and CH2 power stage power supply
4	VO1+	Output pin(+)for channel 1
5	VO1-	CH1 output pin (-) for channel 1
6	VO2+	Output pin(+)for channel 2
7	VO2-	Output pin(-)for channel 2
8	VO3+	Output pin(+)for channel 3
9	VO3-	Output pin(-)for channel 3
10	VO4+	Output pin(+)for channel 4
11	VO4-	Output pin(-)for channel 4
12	VCCP2	CH3 and CH4 power stage powr supply
13	VIN4	Input pin for channel 4
14	VIN4G	Input pin for channel 4(for gain adjustment)
15	VIN3	Input pin for channel 3
16	VIN3G	Input pin for channel 3(for gain adjustment)
17	VIN2	Input pin for channel 2
18	VIN2G	Input pin for channel 2(for gain adjustment)
19	REGIN	External PNP transistor base connection
20	3.3VREG	3.3VREG output pin external PNP transistor,collector connection
21	VCCS	Signal system GND
22	VREFIN	Reference voltage application pin
23	MUTE	Output ON/OFF pin
24	VIN1_SW	CH1 input OP AMP_changeover pin
25	S_GND	Signal system GND
26	VIN1+B	CH1 AMP_B non-inverted input pin
27	VIN1-B	CH1 AMP_B inverted input pin
28	VIN1	CH1 input pin input OP_AMP output pin

4.4 LC75823W (IC601) : LCD driver

- Pin Layout

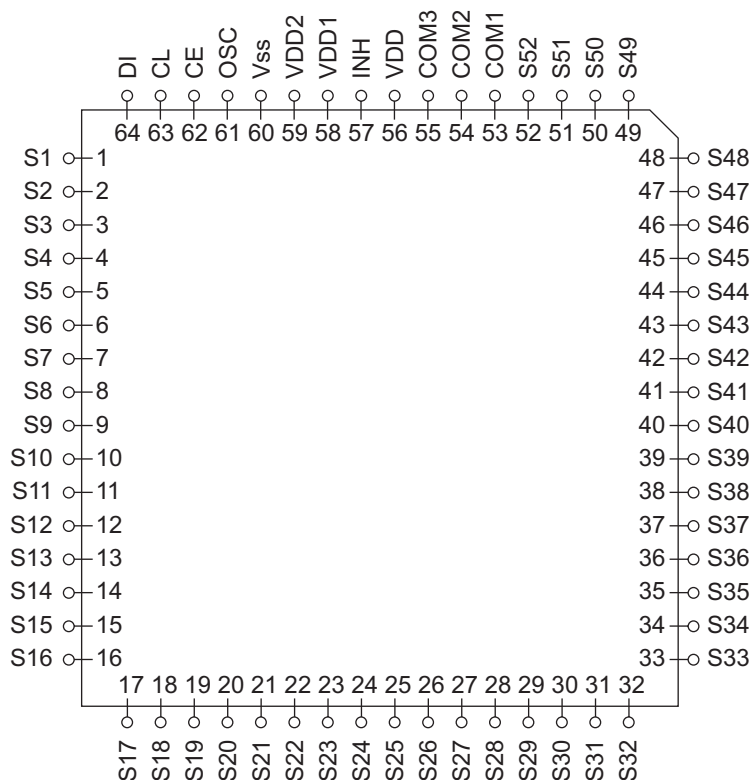

- Pin function

Pin No.	Symbol	I/O	Functions
1 to 52	S1 to S52	O	Segment output pins used to display data transferred by serial data input.
53 to 55	COM1 to COM3	O	Common driver output pins. The frame frequency is given by : $t_0 = (f_{osc}/384)Hz$.
56	VDD	--	Power supply connection. Provide a voltage of between 4.5 and 6.0V.
57	\overline{INH}	I	Display turning off input pin. $\overline{INT} = "L"$ (Vss) ----- off (S1 to S52, COM1 to COM3 = "L") $\overline{INT} = "H"$ (VDD) ----- on Serial data can be transferred in display off mode.
58	VDD1	I	Used for applying the LCD drive 2/3 bias voltage externally. Must be connected to VDD2 when a 1/2 bias drive scheme is used.
59	VDD2	I	Used for applying the LCD drive 1/3 bias voltage externally. Must be connected to VDD1 when a 1/2 bias drive scheme is used.
60	Vss	--	Power supply connection. Connect to GND.
61	OSC	I/O	Oscillator connection. An oscillator circuit is formed by connecting an external resistor and capacitor at this pin.
62	CE	I	Serial data interface connection to the controller. CE : Chip enable
63	CL	I	Serial data interface connection to the controller. CL : Sync clock
64	DI	I	Serial data interface connection to the controller. DI : Transfer data

4.5 NJM4565M-WE (IC571) : CD L.P.F.

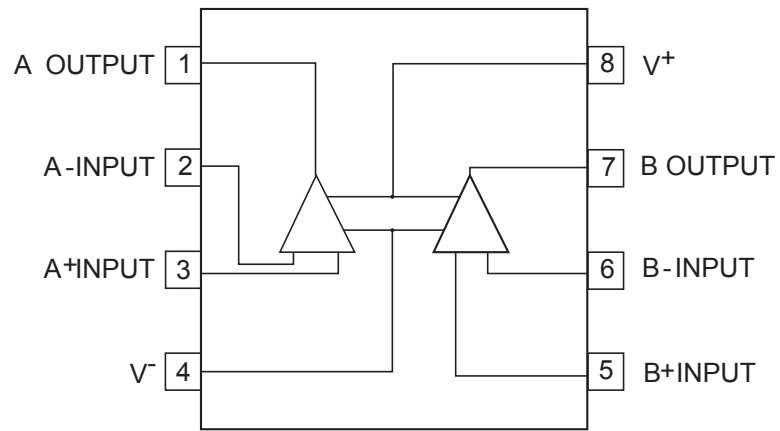

4.6 IC-PST600M/G/-W (IC702) : System reset

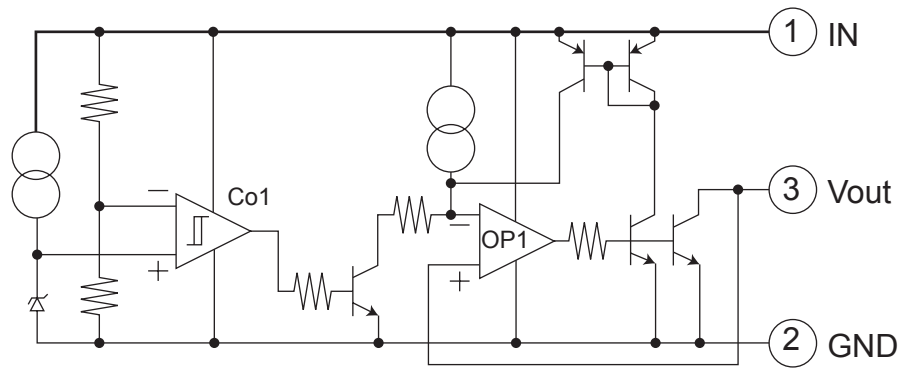

4.7 TA2157FN-X (IC501) : RF amp

- Terminal layout

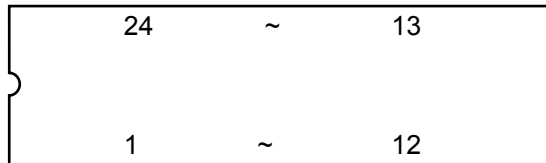

- Block diagram

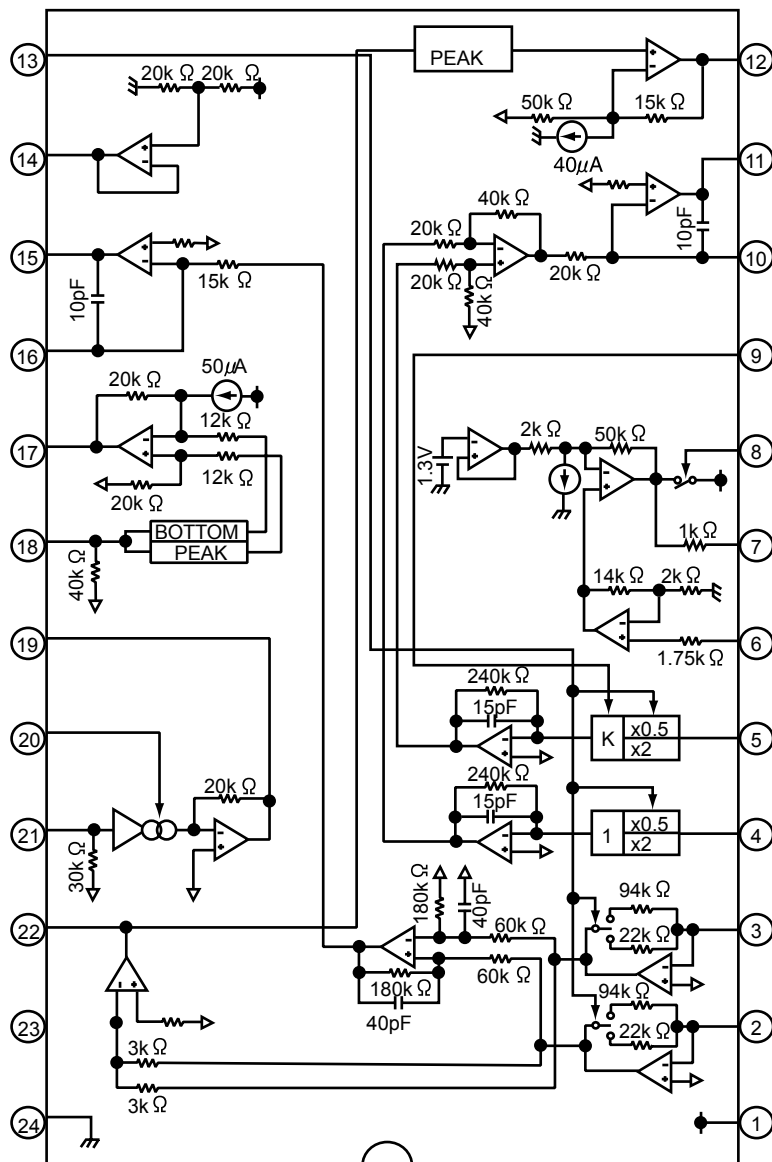

PIN	SEL (APC SW)	TEB (TE BAL)	RFGC (AGC Gian)	TEB (TE BAL)
VCC	APC ON	-50%	+12dB	Normal mode (0dB)
HiZ	APC ON	0%	+6dB	Normal mode (0dB)
GND	APC OFF (LDO=H)	50%	0dB	CD-RW mode (+12dB)

• Pin function

Pin No.	Symbol	I/O	Function												
1	VCC	-	3.3V power supply pin												
2	FNI	I	Main-beam amp input pin												
3	FPI	I	Main-beam amp input pin												
4	TPI	I	Sub-beam amp input pin												
5	TNI	I	Sub-beam amp input pin												
6	MDI	I	Monitor photo diode amp input pin												
7	LDO	O	Laser diode amp output pin												
8	SEL	I	APC circuit ON/OFF control signal, laser diode (LDO) control signal input or bottom/peak detection frequency change pin. <table border="1" data-bbox="662 548 1321 743"> <thead> <tr> <th>SEL</th> <th>APC circuit</th> <th>LDO</th> </tr> </thead> <tbody> <tr> <td>GND</td> <td>OFF</td> <td>Connected VCC through 1kΩ resistor</td> </tr> <tr> <td>Hiz</td> <td>ON</td> <td>Control signal output</td> </tr> <tr> <td>VCC</td> <td>ON</td> <td>Control signal output</td> </tr> </tbody> </table>	SEL	APC circuit	LDO	GND	OFF	Connected VCC through 1kΩ resistor	Hiz	ON	Control signal output	VCC	ON	Control signal output
SEL	APC circuit	LDO													
GND	OFF	Connected VCC through 1kΩ resistor													
Hiz	ON	Control signal output													
VCC	ON	Control signal output													
9	TEB	I	Tracking error balance adjustment signal input pin Adjusts TE signal balance by eliminating carrier component from PWM signal (3-state output, PWM carrier = 88.2kHz) output from TC94A14F/FA TEBC pin using RC-LPF and inputting DC. TEBC input voltage:GND~VCC												
10	TEN	I	Tracking error signal generation amp negative-phase input pin												
11	TEO	O	Tracking error signal generation amp output pin. Combining TEO signal RFRP signal with TC94A14F/FA configures tracking search system.												
12	RFDC	O	RF signal peak detection output pin												
13	GVSW	I	AGC/FE/TE amp gain change pin <table border="1" data-bbox="867 1100 1117 1295"> <thead> <tr> <th>GVSW</th> <th>Mode</th> </tr> </thead> <tbody> <tr> <td>GND</td> <td>CD-RW</td> </tr> <tr> <td>Hiz</td> <td>Normal</td> </tr> <tr> <td>VCC</td> <td></td> </tr> </tbody> </table>	GVSW	Mode	GND	CD-RW	Hiz	Normal	VCC					
GVSW	Mode														
GND	CD-RW														
Hiz	Normal														
VCC															
14	VRO	O	Reference voltage (VRO) output pin *VRO=1/2VCC When VCC=3.3V												
15	FEO	O	Focus error signal generation amp output pin												
16	FEN	I	Focus error signal generation amp negative-phase input pin												
17	RFRP	O	Signal amp output pin for track count Combining RFRP signal and TEO signal with TC94A14F/FA configures tracking search system.												
18	REIS	I	RF signal amplitude adjustment amp output pin Adjusts RF signal amplitude by eliminating carrier component from PWM signal (3-state output, PWM carrier=88.2kHz)output fromTC94A14F/14FA *RFGC pin using RC-LPF and inputting DC. *RFGC input voltage:GND~VCC												
19	RFGO	O													
20	RFGC	I													
21	AGCIN	I	RF signal amplitude adjustment amp input pin												
22	RFO	O	RF signal generation amp output pin												
23	RFI	I	RF signal generation amp input pin												
24	GND	-	GND pin												

4.8 TC94A14FA (IC521) : DSP & DAC

• Terminal layout & block diagram

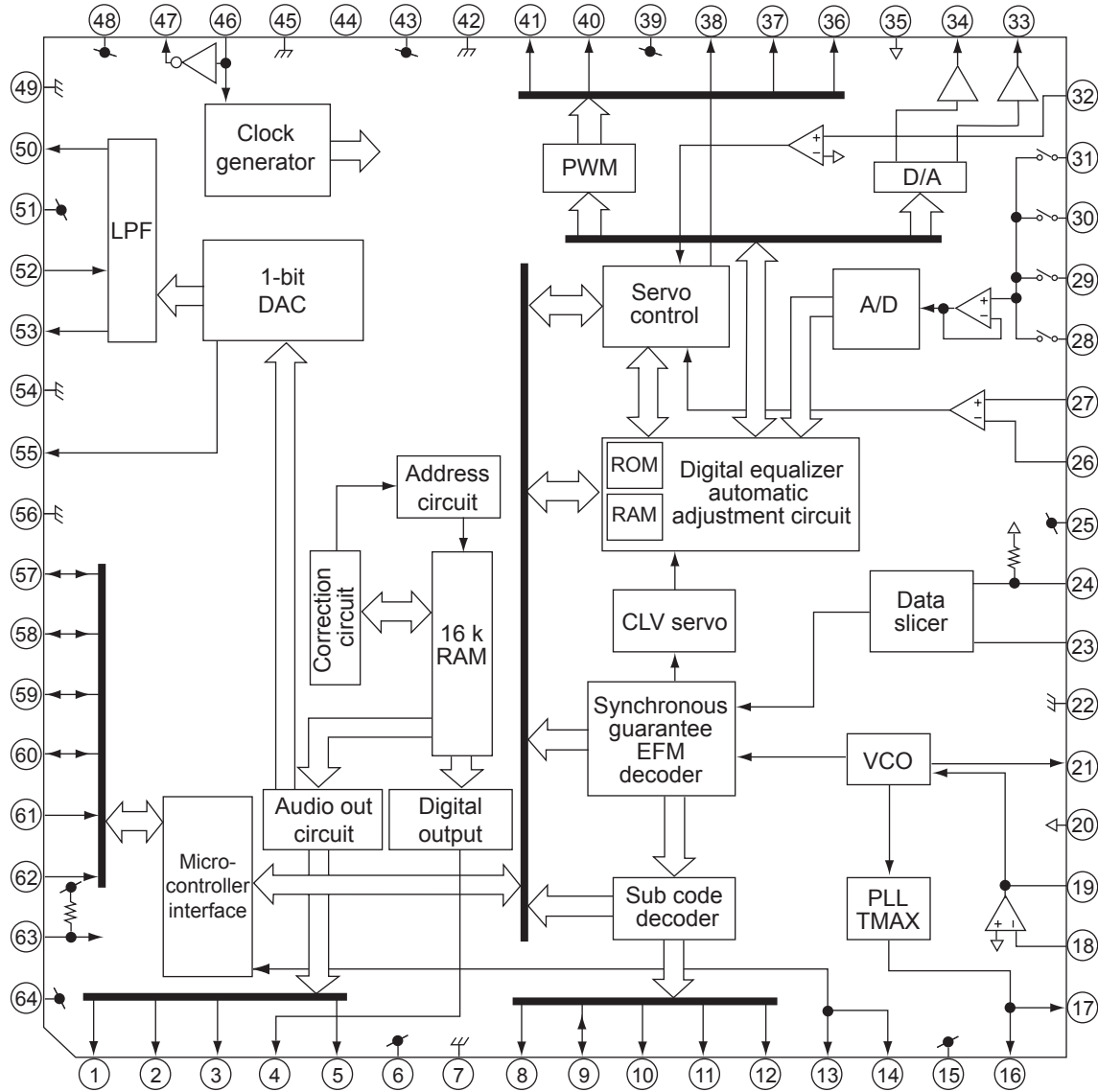

• Pin function

Pin No	Symbol	I/O	Description
1	BCK	O	Bit clock output pin. 32fs/48fs or 64fs selectable by command.
2	LRCK	O	L/R channel clock output pin. "L" for L channel and "H" for R channel. Output polarity can be inverted by command.
3	AOUT	O	Audio data output pin. MSB-first or LSB-first selectable by command.
4	DOUT	O	Digital data output pin. Outputs up to double-speed playback.
5	IPF	O	Correction flag output pin. When set to "H" AOUT output cannot be corrected by C2 correction processing.
6	V _{DD3}	-	Digital 3.3V power supply voltage pin.
7	V _{SS3}	-	Digital GND pin.
8	SBOK	O	Subcode Q data CRCC result output pin. "H" level when result is OK.
9	CLCK	O	Subcode P-W data read I/O pin. I/O polarity selectable by command.
10	DATA	O	Subcode P-W data output pin.
11	SFSY	O	Playback frame sync signal output pin.
12	SBSY	O	Subcode block sync signal output pin. "H" level at S1 when subcode sync is detected.
13	HSO	I/O	General-purpose input / output pins. Input port at reset.
14	UHSO		
15	PV _{DD3}	-	PLL-only 3.3V power supply voltage pin.
16	PDO	O	EFM and PLCK phase difference signal output pin.

Pin No	Symbol	I/O	Description	
17	TMAX	O	TMAX detection result output pin.	
			TMAX Detection Result	TMAX Output
			Longer than fixed period	"PVDD3"
			Shorter than fixed period	"AVSS3"
18	LPFN	I	Inverted input pin for PLL LPF amp.	
19	LPFO	O	Output pin for PLL LPF amp.	
20	PVREF	-	PLL-only VREF pin.	
21	VCOF	O	VCO filter pin.	
22	AV _{SS3}	-	Analog GND pin.	
23	SLCO	O	DAC output pin for data slice level generation.	
24	RFI	I	RF signal input pin. Zin selectable by command.	
25	AV _{DD3}	-	Analog 3.3V power supply voltage pin.	
26	RFCT	I	RFRP signal center level input pin.	
27	RFZI	I	RFRP signal zero-cross input pin.	
28	RFRP	I	RF ripple signal input pin.	
29	FEI	I	Focus error signal input pin.	
30	SBAD	I	Sub-beam adder signal input pin.	
31	TEI	I	Tracking error input pin. Inputs when tracking servo is on.	
32	TEZI	I	Tracking error signal zero-cross input pin.	
33	FOO	O	Focus equalizer output pin.	
34	TRO	O	Tracking equalizer output pin.	
35	VREF	-	Analog reference power supply voltage pin.	
36	RFGC	O	RF amplitude adjustment control signal output pin.	
37	TEBC	O	Tracking balance control signal output pin.	
38	SEL	O	APC circuit ON/OFF signal output pin. At laser on, high impedance with UHS="L", H output with UHS="H".	
39	AV _{DD3}	-	Analog 3.3V power supply voltage pin.	
40	FMO	O	Feed equalizer output pin.	
41	DMO	O	Disc equalizer output pin.	
42	V _{SS3}	-	Digital GND pin.	
43	V _{DD3}	-	Digital 3.3V power supply voltage pin.	
44	TESIN	I	Test input pin. Normally, fixed to "L".	
45	XV _{SS3}	-	System clock oscillator GND pin.	
46	XI	I	System clock oscillator input pin.	
47	XO	O	System clock oscillator output pin.	
48	XV _{DD3}	-	System clock oscillator 3.3V power supply voltage pin.	
49	DV _{SS3R}	-	DA converter GND pin.	
50	RO	O	R-channel data forward output pin.	
51	DV _{DD3}	-	DA converter 3.3V power supply pin.	
52	DVR	-	Reference voltage pin.	
53	LO	O	L-channel data forward output pin.	
54	DV _{SS3L}	-	DA converter GND pin.	
55	ZDET	O	1 bit DA converter zero detection flag output pin.	
56	V _{SS5}	-	Microcontroller interface GND pin.	
57	BUS0			
58	BUS1			
59	BUS2	I/O	Microcontroller interface data I/O pins.	
60	BUS3			
61	BUCK	I	Microcontroller interface clock input pin.	
62	/CCE	I	Microcontroller interface chip enable signal input pin. At "L", BUS0 to BUS3 are active.	
63	/RST	I	Reset signal input pin. At reset, "L".	
64	V _{DD5}	-	Microcontroller interface 5V power supply pin.	

4.9 TB2118F-X (IC31) : PLL

• Terminal Layout

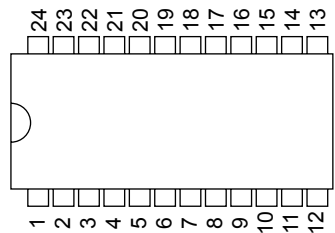

• Block diagram

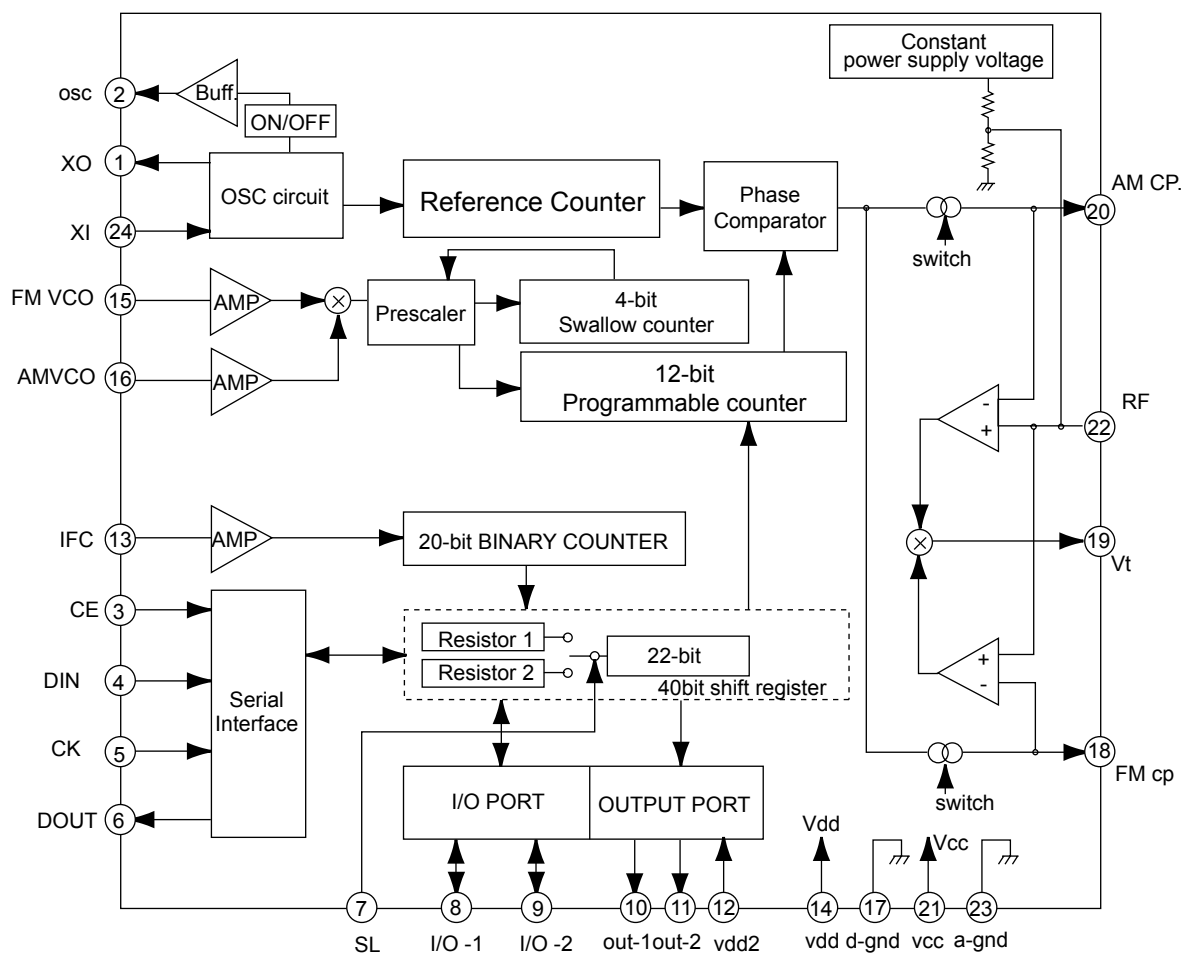

• Pin Function

Pin No.	Symbol	I/O	Function	Pin No.	Symbol	I/O	Function
1	XOUT	O	Crystal oscillator pin	13	IFC	I	IF signal input
2	OSC	-	Non connect	14	VDD	-	Power pins for digital block
3	CE	I	Chip enable input	15	FMIN	I	FM band local signal input
4	DI	I	Serial data input	16	AMIN	I	AM band local signal input
5	CK	I	Clock input	17	DGND	-	Connect to GND (for digital circuit)
6	DOUT	O	Serial data output	18	FMCP	O	Charge pump output for FM
7	SR	O	Register control pin	19	Vt	-	Tuning voltage biased to 2.5V.
8	I/O1	I/O	I/O ports	20	AMCP	O	Charge pump output for AM
9	I/O2	I/O	I/O ports	21	VCC	-	Power pins for analog block
10	OUT1	-	Non connect	22	RF	I	Ripple filter connecting pin
11	OUT2	-	Non connect	23	AGND	-	Connect to GND (for analog circuit)
12	VDD2	-	Single power supply for REF. frequency block	24	XIN	I	Crystal oscillator pin

4.10 TEA6320T-X (IC161) : E.volume

- Pin layout

SDA	1	32	SCL
GND	2	31	VCC
OUTLR	3	30	OUTRR
OUTLF	4	29	OUTRF
TL	5	28	TR
B2L	6	27	B2R
B1L	7	26	B1R
IVL	8	25	IVR
ILL	9	24	ILR
QSL	10	23	QSR
IDL	11	22	IDR
MUTE	12	21	Vref
ICL	13	20	ICR
IMD	14	19	CAP
IBL	15	18	IBR
IAL	16	17	IAR
			CD-CH
			TAPE
			TUNER

- Block diagram

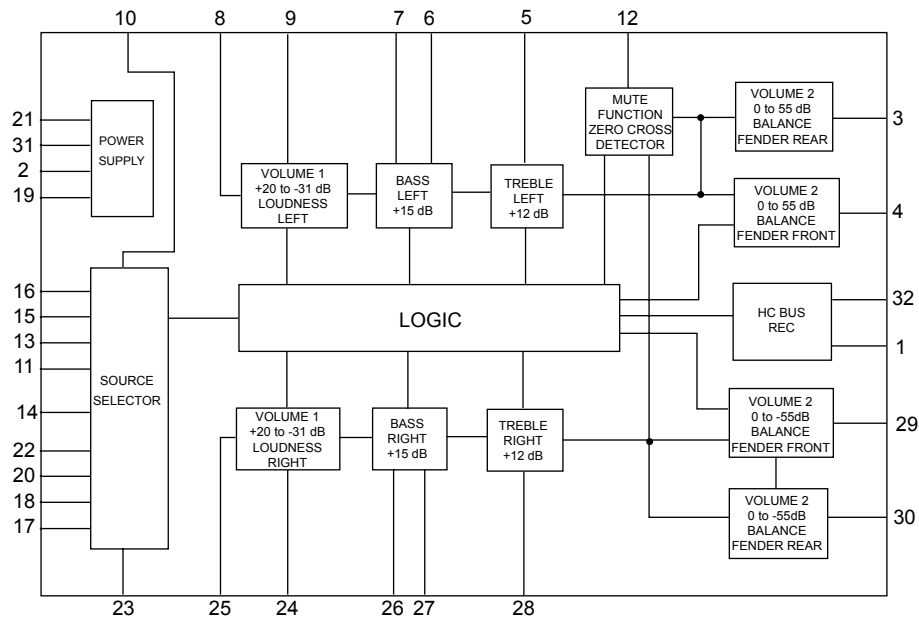

- Pin functions

Pin No.	Symbol	I/O	Functions
1	SDA	I/O	Serial data input/output.
2	GND	-	Ground.
3	OUTLR	O	output left rear.
4	OUTLF	O	output left front.
5	TL	I	Treble control capacitor left channel or input from an external equalizer.
6	B2L	-	Bass control capacitor left channel or output to an external equalizer.
7	B1L	-	Bass control capacitor left channel.
8	IVL	I	Input volume 1. left control part.
9	ILL	I	Input loudness. left control part.
10	QSL	O	Output source selector. left channel.
11	IDL	-	Not used
12	MUTE	-	Not used
13	ICL	I	Input C left source.
14	IMO	-	Not used
15	IBL	I	Input B left source.
16	IAL	I	Input A left source.

Pin No.	Symbol	I/O	Functions
17	IAR	I	Input A right source.
18	IBR	I	Input B right source.
19	CAP	-	Electronic filtering for supply.
20	ICR	I	Input C right source.
21	Vref	-	Reference voltage (0.5Vcc)
22	IDR	-	Not used
23	QSR	O	Output source selector right channel.
24	ILR	I	Input loudness right channel.
25	IVR	I	Input volume 1. right control part.
26	B1R	-	Bass control capacitor right channel
27	B2R	O	Bass control capacitor right channel or output to an external equalizer.
28	TR	I	Treble control capacitor right channel or input from an external equalizer.
29	OUTRF	O	Output right front.
30	OUTRR	O	Output right rear.
31	Vcc	-	Supply voltage.
32	SCL	I	Serial clock input.

4.11 UPD784215AGC224 (IC701) : CPU

• Pin Layout

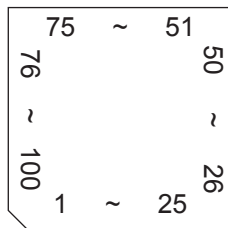

• Pin function

Pin No.	Symbol	I/O	function
1~2	no use	O	output L
3	SW2	I	CD mecha SW2
4	PSW	I	CD mecha Position Setting SW
5	LM	O	loading motor control output
6	MOTOR SEL	O	Loading/feed motor selecting output
7~8	no use	O	output L
9	VDD		maicon power supply
10	X2		
11	X1		
12	VSS	-	GND
13	XT2		
14	XT1		
15	RESET	I	SYSTEM RESET
16	SW1	I	CD mecha sw1
17	no use	O	output L
18	PS2	I	power save2, H means STOP mode
19~22	no use	O	output L
23	AVDD		A/D converter power supply
24	AVREF0		A/D reference voltage
25	VOLÇP	I	volume encoder pulse input 1
26	VOLÇQ	I	volume encoder pulse input 2
27	KEY0	I	key input 0
28	KEY1	I	key input 1
29	KEY2	I	key input 2
30	LEVEL	I	level meter input
31	no use	I	Input
32	SM	I	S DMETER input
33	AVSS	-	GND
34~35	no use	O	output L
36	AVREF		
37~40	no use	O	output L
41	LCD-DA	O	data output for LCD driver
42	LCD-SCK	O	CLK output for LCD driver
43	LCD-CE	O	CE for LCD driver
44	no use	O	output L
45	E2PROM-DI	I	I2C data input
46	E2PROM-DO	O	I2C data output

Pin No.	Symbol	I/O	function
47	E2PROM-CLK	O	I2C clock output
48~50	no use	O	output L
51	no use	O	output L
53	SD/ST	I	station detector or stereo indicator input ; H means a station is there. L means the program is stereo.
54	no use	O	output L
55	MONO	O	monoral selection output ; H means monoral
56~60	no use	O	output L
61	DETACH	I	detach detect input ; H means detaching
62	no use	O	output L
63	SEEK/STOP	O	auto seek and stop selecting output ; H means seeking, L means receiving.
64	IFC CONT	O	IFC control output
65	FM/AM	O	FM, AM band selecting output ; H = FM CL= AM
66	PLL-CE	O	CE output for PLL IC
67	PLL-DO	O	data output for PLL IC
68	PLL-CLK	O	clock output for PLL IC
69	PLL-DI	I	data input from PLL IC
70	TEL-MUTING	I	telephone muting detection input ; Active level can be selected H or L in PSM
71	no use	O	output L
72	VSS	-	GND
73	no use	I	output L
74	PS1	I	POWER SAVE1 Çk= ACC off
75	POWER	O	POWER ON/OFF control output H=power on
76	CD-ON	O	CD power supply control output H=CD power on
77	MUTING	O	muting output L=muting on
78~80	no use	O	output L
81	VDD	-	maicon power supply
82	no use	O	output L
83	VOL-DA	O	data output for e-vol IC
84	VOL-CLK	O	clock output for e-vol IC
85~88	no use	I	output L
89~90	no use	I	output L
91	BUCK	O	clock output for CD LSI
92	CCE	O	CE output for CD LSI
93	RST	O	reset output for CD LSI
94	TEST		for rewriting flash memory
95	BUS0	I/O	data output and input 0 for CD LSI
96	BUS1	I/O	data output and input 1 for CD LSI
97	BUS2	I/O	data output and input 2 for CD LSI
98	BUS3	I/O	data output and input 3 for CD LSI
99	no use	O	output L
100	CD-RW		RF gain control L=CD-RW, H=CD-DA



VICTOR COMPANY OF JAPAN, LIMITED
AV & MULTIMEDIA COMPANY MOBILE ENTERTAINMENT CATEGORY 10-1,1chome,Ohwatari-machi,Maebashi-city,371-8543,Japan

(No.49822)

JVC

SCHEMATIC DIAGRAMS

CD RECEIVER

KD-S747

CD-ROM No.SML200303

Area suffix
EE -----Russian Federation

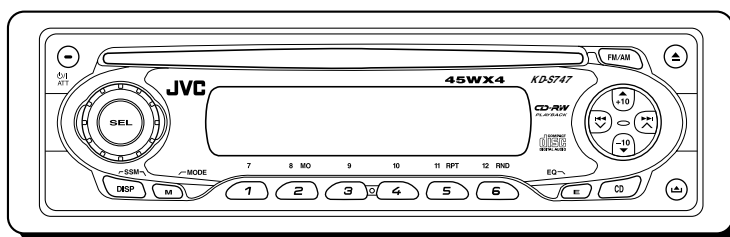
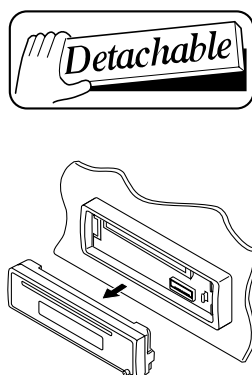

COMPACT
disc
DIGITAL AUDIO

CD-RW
PLAYBACK

Contents

Block diagram	2-1
Standard schematic diagrams	2-2
Printed circuit boards	2-5~7

Safety precaution

 **CAUTION** Burrs formed during molding may be left over on some parts of the chassis. Therefore, pay attention to such burrs in the case of performing repair of this system.

 **CAUTION** Please use enough caution not to see the beam directly or touch it in case of an adjustment or operation check.

Block diagram

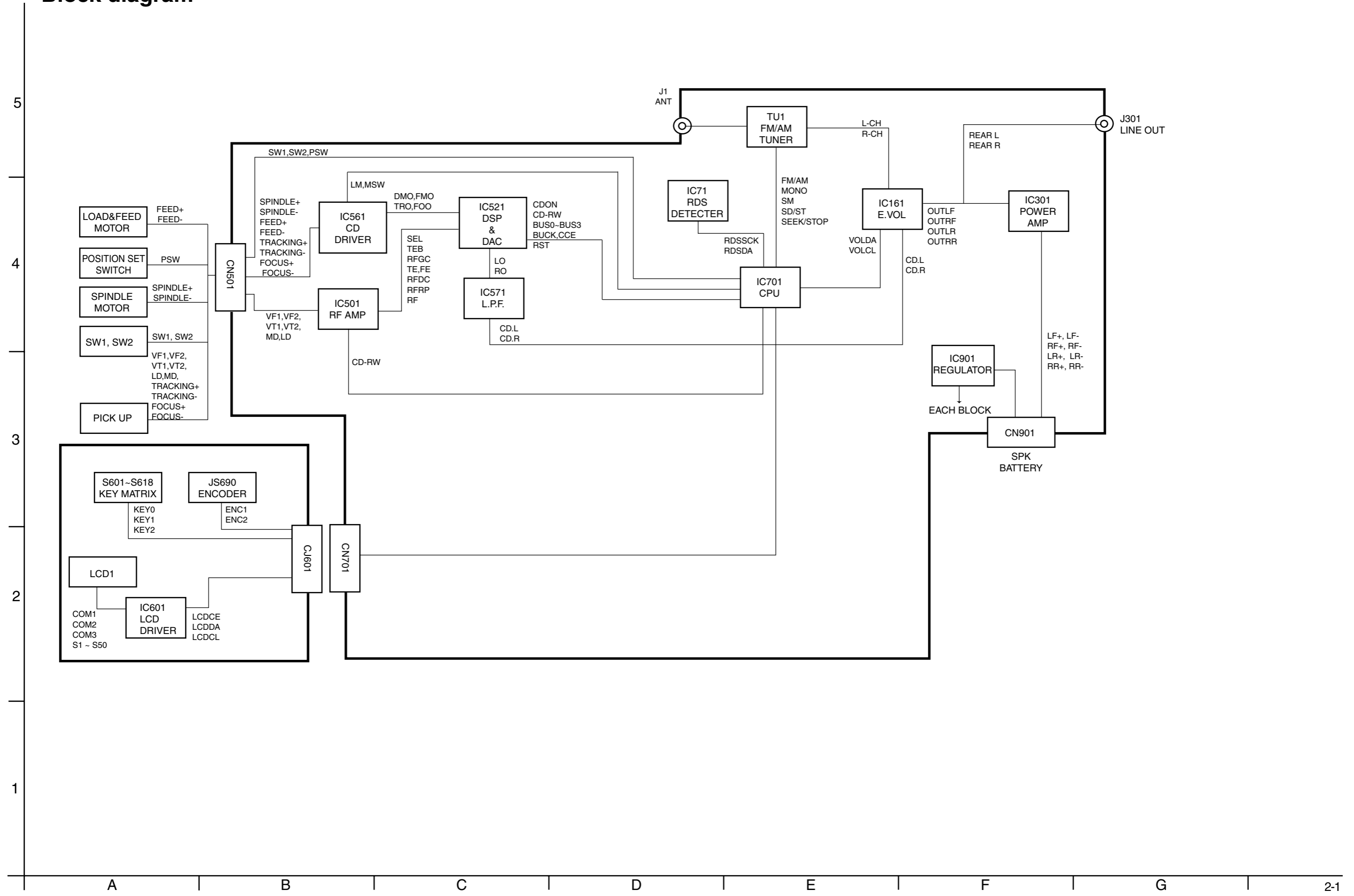

Standard schematic diagrams

Main amplifier section

- NOTES
1. VOLTAGES ARE DC-MEASURED WITH A DIGITAL VOLT METER WITHOUT INPUT SIGNAL CONDITION—FM MODE. □ AM MODE. | CD MODE.
 2. UNLESS OTHERWISE SPECIFIED:
ALL RESISTORS ARE 1/4W 25% METAL GLAZE RESISTOR.
ALL CAPACITORS ARE 50V OR 25V CERAMIC CAPACITOR.
ALL RESISTANCE VALUES ARE IN OHM.
ALL CAPACITANCE VALUES ARE IN μF (μP OR PF)
ALL C CAPACITORS ARE SHOWN IN THE FORM OF CAPACITANCE(μF)/RATED VOLTAGE(V)
ALL INDUCTOR VALUES ARE IN μH .
 3. COMPONENTS IN () INDICATE NOT USE.

FRONT R
A. GND
FRONT L
REAR R
A. GND
REAR L

	10K	UN2211-X
	10K	UN2111-X

LINE OUTPUT

NOT USED

POWER AMP.

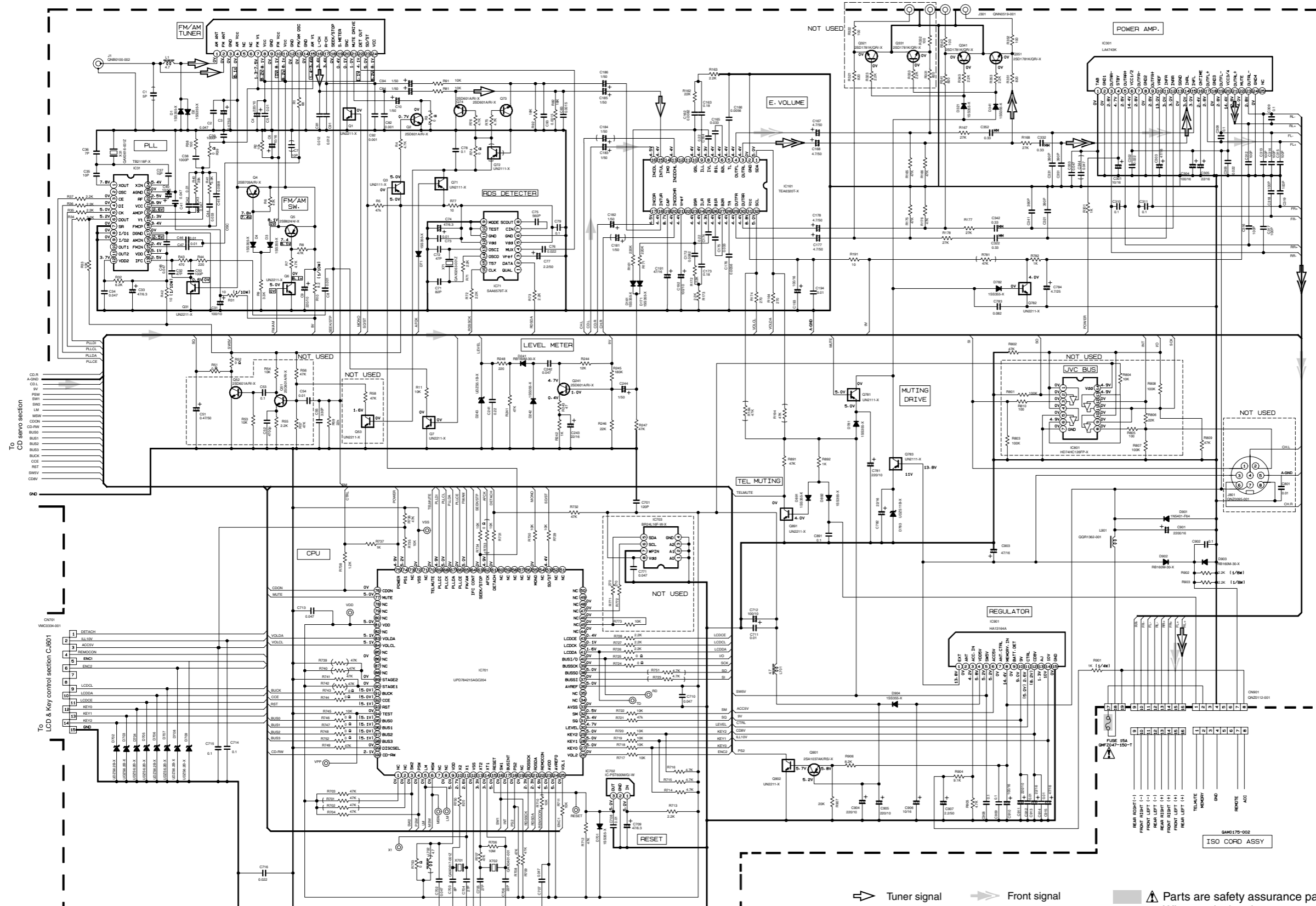

5
4
3
2
1

To CD servo section

To LCD & Key control section CUB01

MAIN PWB GEB10074A

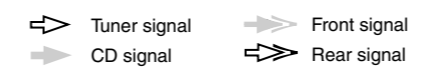

Parts are safety assurance parts. When replacing those parts make sure to use the specified one.

A B C 2-2 D E F G H

CD servo control section

5
4
3
2
1

	10K		UN2211-X
	10K		UN2211-X

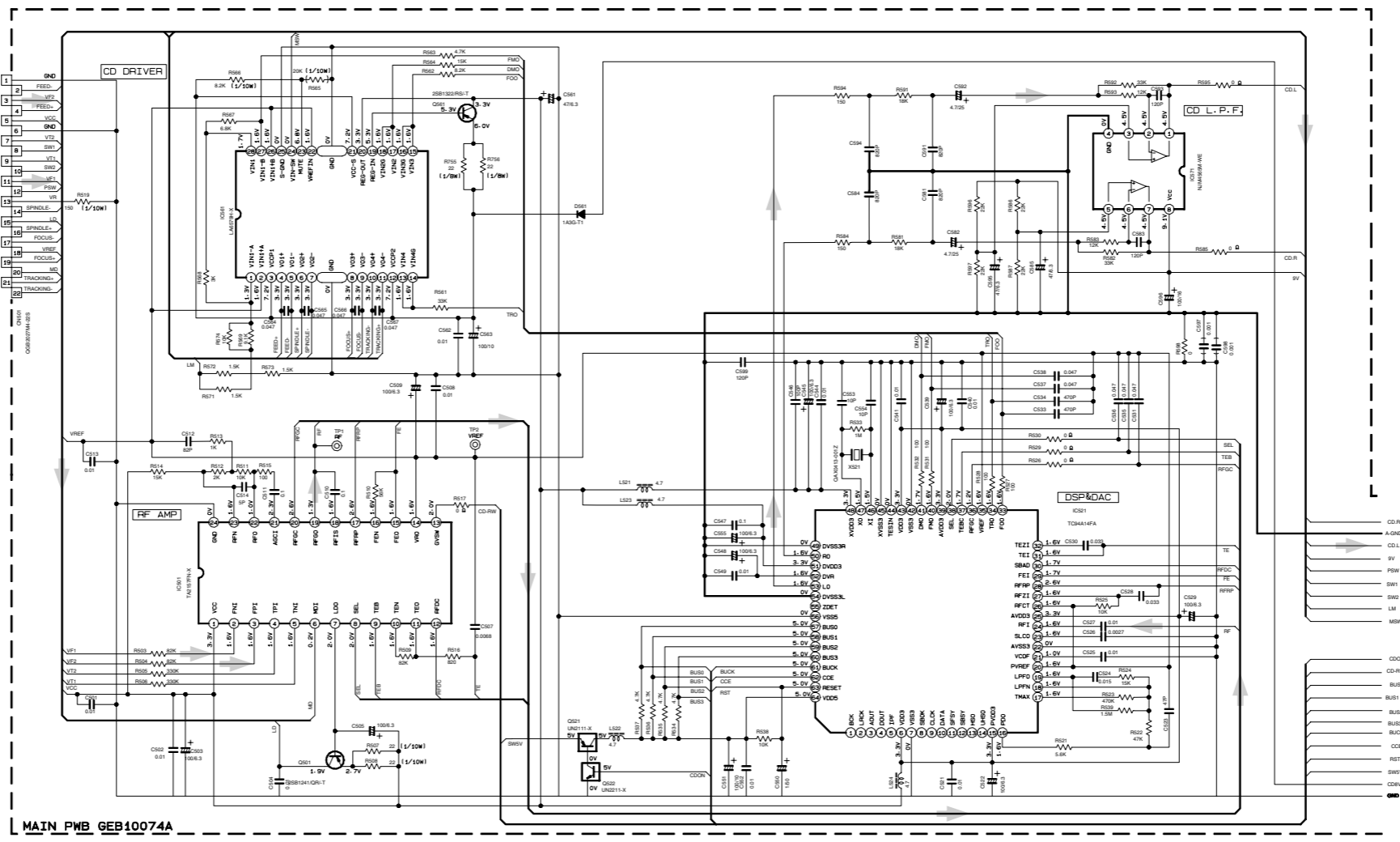
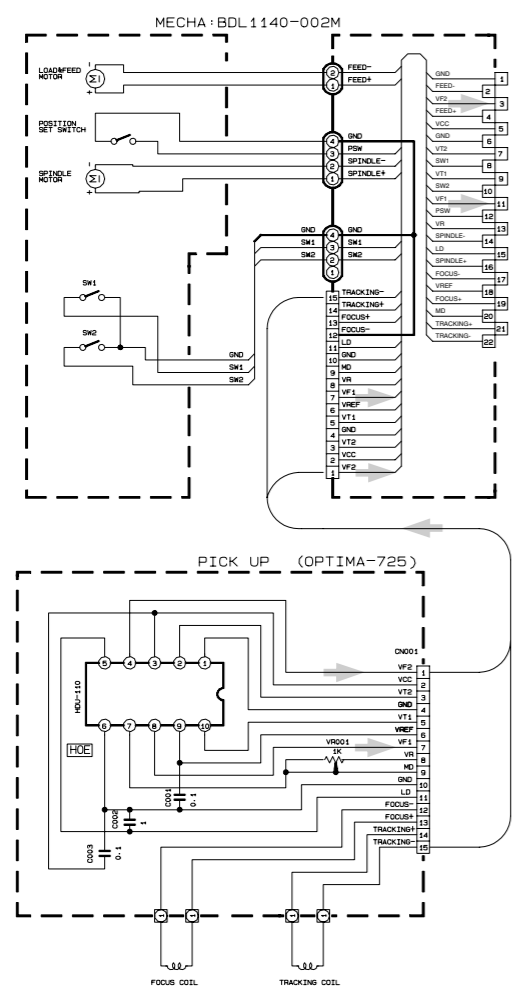

To Main amplifier section

➔ CD signal

- NOTES
1. VOLTAGES ARE DC-MEASURED WITH A DIGITAL VOLT METER WITHOUT INPUT SIGNAL CONDITION — CD MODE.
 2. UNLESS OTHERWISE SPECIFIED, ALL RESISTORS ARE 1/10W ±5% METAL GLAZE RESISTOR. ALL CAPACITORS ARE 50V OR 25V CERAMIC CAPACITOR. ALL RESISTANCE VALUES ARE IN OHM. ALL CAPACITANCE VALUES ARE IN UF (p=PF) ALL INDUCTOR VALUES ARE IN UH. ALL E-CAPACITORS ARE SHOWN IN THE FORM OF CAPACITANCE(UF)/RATED VOLTAGE(V)

LCD & Key control section

5

4

3

2

1

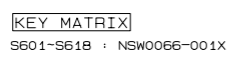
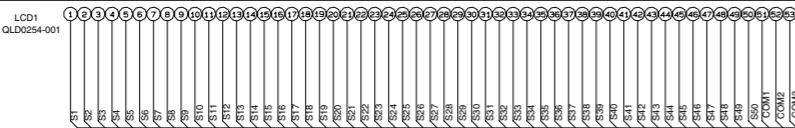
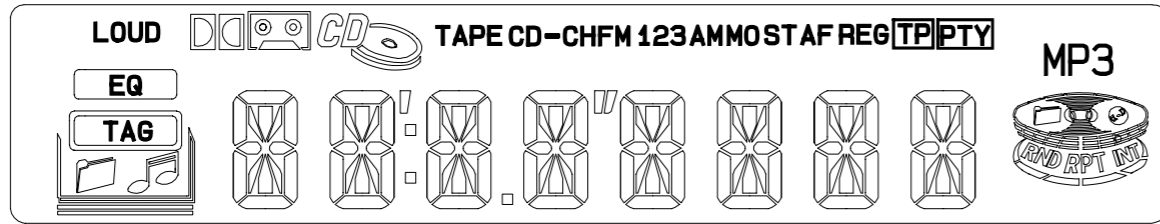

SW PWB GEB10068A

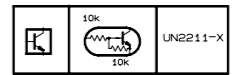
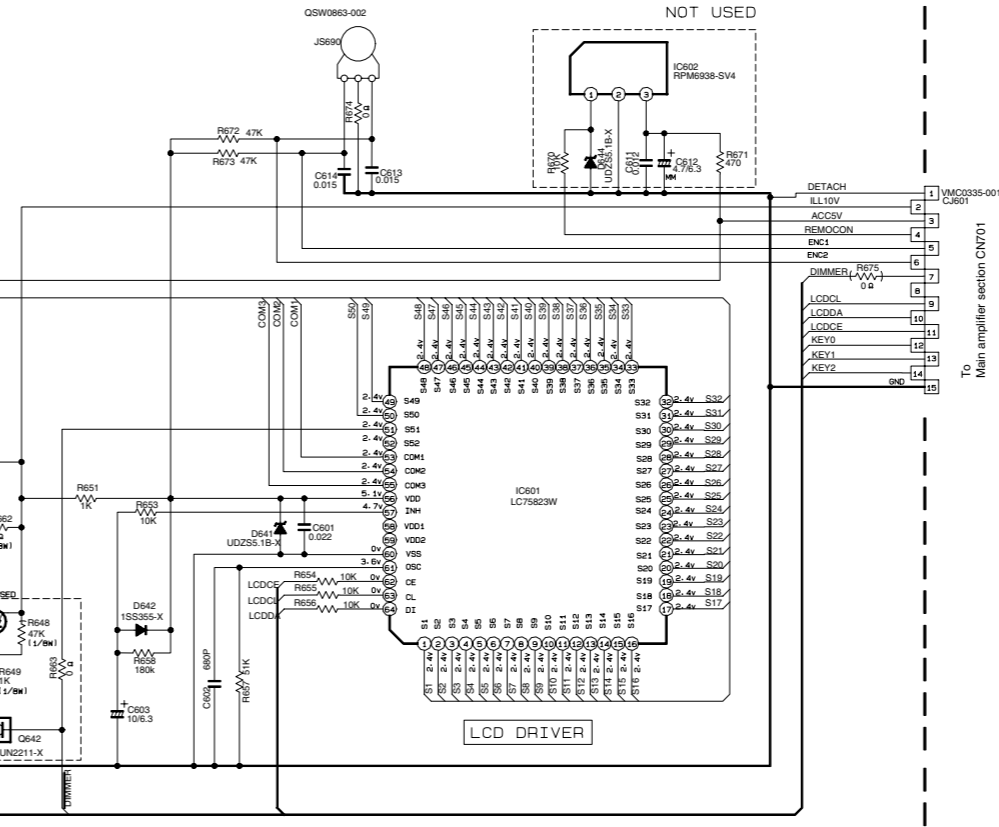

- NOTES
1. VOLTAGES ARE DC-MEASURED WITH A DIGITAL VOLT METER WITHOUT INPUT SIGNAL.
 2. UNLESS OTHERWISE SPECIFIED:
 ALL RESISTOR ARE 1/16W 45% METAL GLAZE RESISTOR.
 ALL CAPACITORS ARE 50V OR 25V CERAMIC CAPACITOR.
 ALL RESISTANCE VALUES ARE IN OHM.
 ALL CAPACITANCE VALUES ARE IN uF (P=PF)
 ALL E. CAPACITORS ARE SHOWN IN THE FORM OF CAPACITANCE(uF)/RATED VOLTAGE
 MM --- TANTAL CAPACITOR.

Printed circuit boards

■ Main board

5

Forward side

4

3

2

1

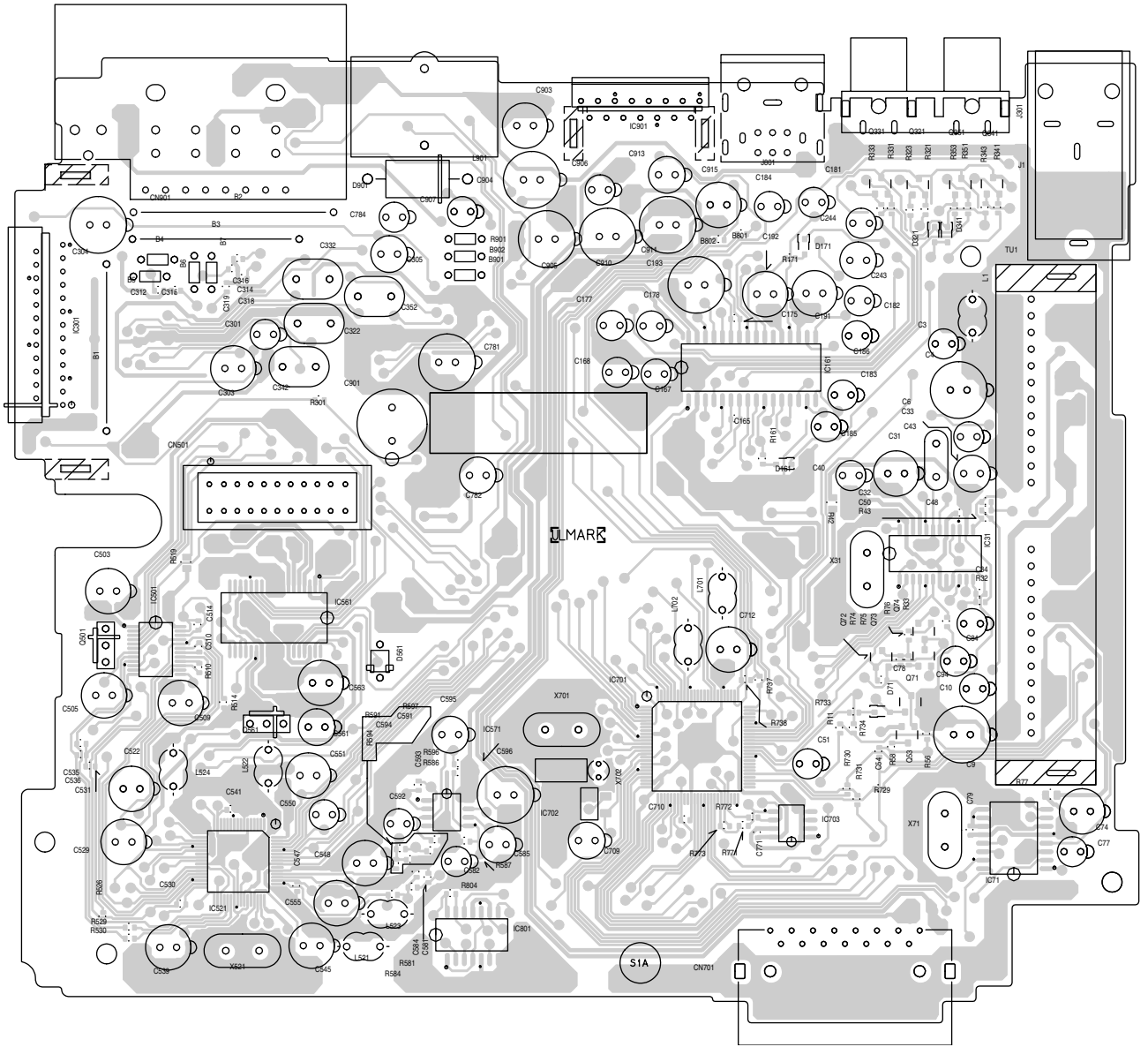

A

B

C

■ Main board

Reverse side

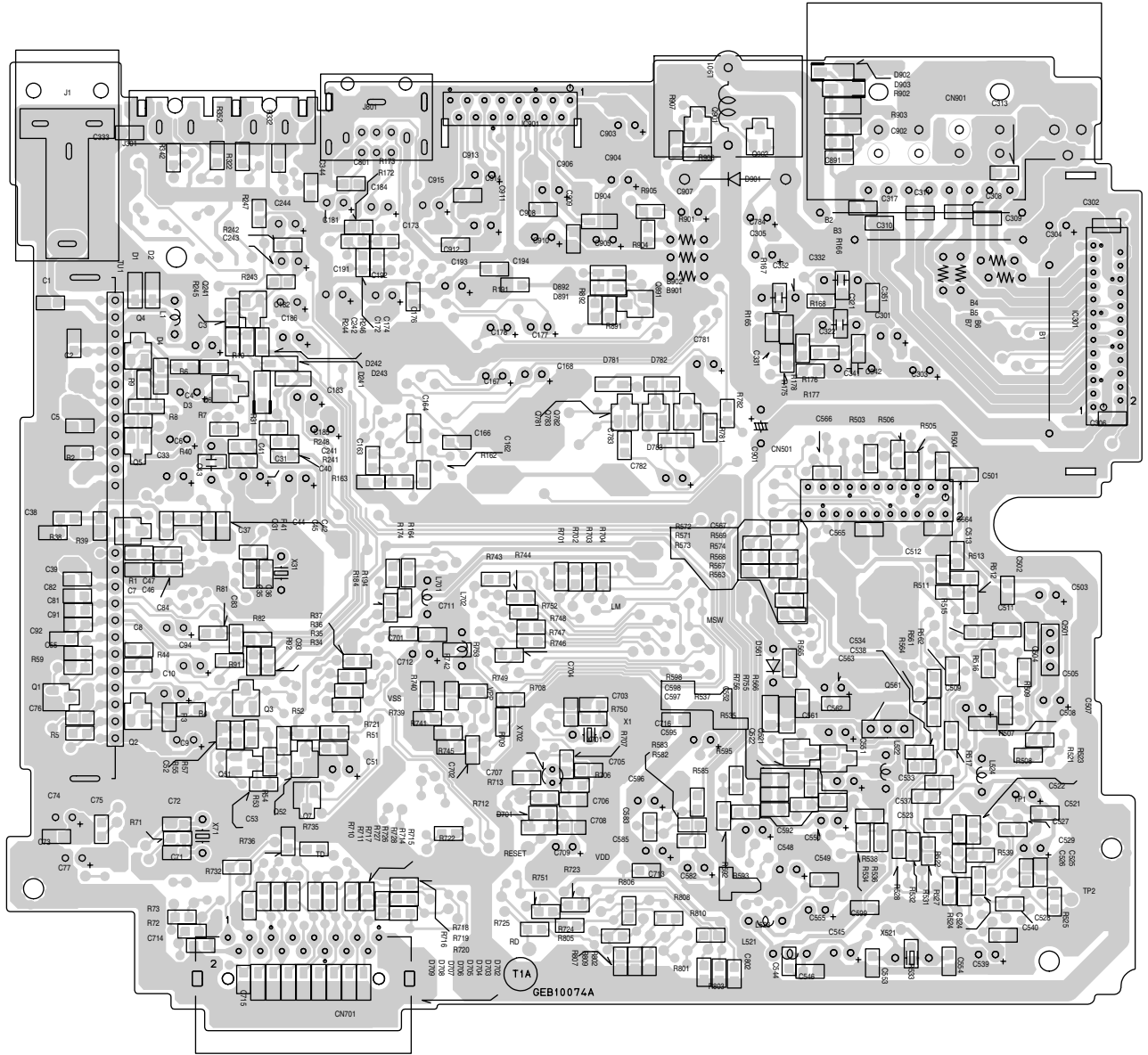

■ Front board

5

Forward side

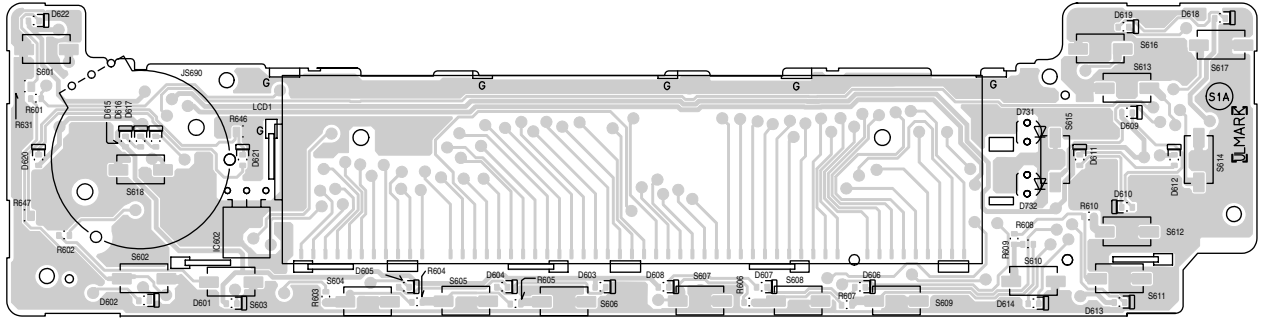

4

3

Reverse side

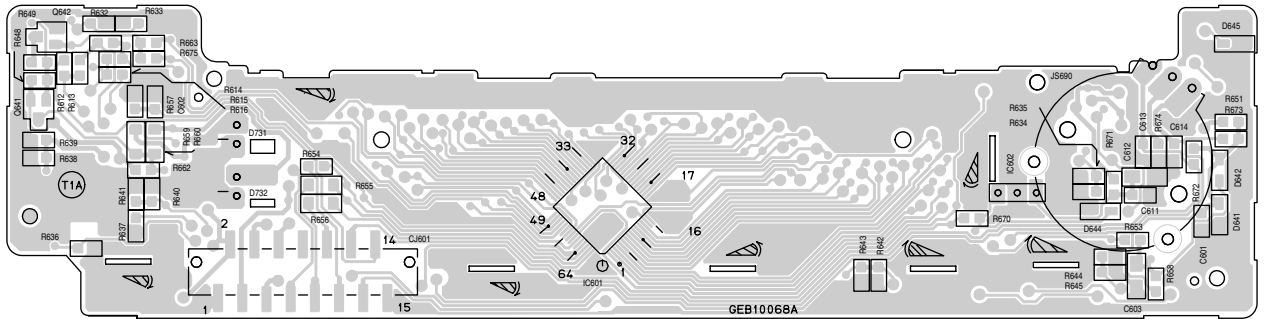

2

1

A

B

C

KD-S747

JVC

VICTOR COMPANY OF JAPAN, LIMITED

AV & MULTIMEDIA COMPANY 10-1, 1Chome, Ohwatari-machi, Maebashi-city, 371-8543, Japan

(No.49822SCH)



Printed in Japan
2003/03